

CsIII User Guide

Model 4310B

CsIII User Guide
Installation, Configuration, and Operation
Part #: 13894-201, Rev. K

NOTICE

Symmetricom, Inc. provides this manual “as is” without warranty of any kind, expressed or implied, including, but not limited to the implied warranties of merchantability and fitness for a particular purpose. Symmetricom may make improvements and or change in the product(s) and or the program(s) described in this manual at any time and without notice.

This publication could contain technical inaccuracies or typographical errors. Changes are periodically made to the information herein; these changes will be incorporated in new editions of this publication.

Symmetricom may use or distribute any of the information you supply in any way it believes appropriate without incurring any obligations whatever.

© Copyright Symmetricom, Inc. 2008

The information and/or drawings set forth in this document and all rights in and to inventions disclosed herein which might be granted thereon disclosing or employing the materials, methods, techniques or apparatus described herein, are the exclusive property of Symmetricom, Inc.

WARRANTY

Symmetricom, Inc. warrants for one year after delivery to the original purchaser of any product manufactured by Symmetricom, that it shall be free of defects in material and workmanship. Obligation under this warranty shall be limited to repair or replacement, at Symmetricom's discretion, of any product or part thereof that has been returned by the original purchaser with transportation prepaid, and upon examination by Symmetricom, is found to be defective. Symmetricom assumes no responsibility for loss or damage to equipment being returned for repair or replacement under the terms of this warranty.

For this warranty to be effective, the purchaser agrees that the equipment will be properly installed and maintained. Equipment which, upon examination by Symmetricom, requires repair or replacement of parts thereof as a result of improper installation, misuse, unauthorized alterations or repairs, or user negligence, such repairs or replacement of parts thereof will be made at cost.

Symmetricom makes no representation or warranty of any kind, either expressed or implied, with respect to equipment operation and procedures. Any action that the user may take in reliance upon the operation or accuracy of this equipment shall be taken solely upon the user's own responsibility and risk.

Symmetricom shall not be liable for consequential damages to purchaser, user, or any others resulting from the possession or use of this equipment.

Prior to return of a product under terms of this warranty, Symmetricom, Inc., is to be notified. Notification is to include the model number and serial number of the product and full details of the problem.

AMENDMENT NOTICE

Symmetricom, Inc. makes every attempt to provide up-to-date manuals with the associated equipment. Occasionally, changes are made to the equipment wherein it is necessary to provide amendments to the manual. If any amendments are provided for this manual they are printed on paper stock other than white and will be found at the rear of this manual.

TABLE OF CONTENTS

Chapter 1 - Introduction.....	1
1.1 Who Should Read This User Guide.....	1
1.2 About This User Guide.....	2
1.3 Typographical and Other Conventions.....	2
1.4 Warnings, Cautions, Recommendations, and Notes.....	2
Chapter 2 - Product Overview.....	4
2.1 LED Indicators.....	4
2.2 Rear Panel Connections.....	5
2.3 Software.....	5
2.4 Power.....	5
2.5 Factory Configurations.....	6
Chapter 3 - Installing the CsIII.....	7
3.1 Unpacking Instructions.....	7
3.2 Environmental Considerations.....	7
3.3 Pre-Installation Checklist.....	8
3.4 Tools and Materials.....	8
3.5 Installing the CsIII.....	8
3.6 Installing the Monitor3 Software.....	9
3.7 Establishing Communications.....	10
Chapter 4 - Operation.....	12
4.1 Monitor3 Main Status Window.....	12
4.2 Unit Monitoring and Data Logging.....	13
4.3 Adjusting Output Frequencies.....	15
4.4 Synchronizing to a 1 PPS Source.....	15
4.5 Slewing the Output Phase.....	16
4.6 Alarms.....	17
4.7 Event Logging.....	18
4.8 Factory Settings.....	19
4.9 Communications.....	20
Chapter 5 - Maintenance & Troubleshooting.....	21
5.1 Preventive Maintenance.....	21
5.2 Troubleshooting.....	22
5.3 Shipping.....	22
5.3.1 Hazardous Material (HAZMAT) Shipping Considerations.....	22
5.3.2 Shipping Products Back to the Factory.....	22
5.3.3 Shipping Carriers.....	23
5.4 Storage.....	24
5.4.1 Cesium Beam Tube Vacuum.....	25
5.4.2 Cesium Beam Tube Shelf Life.....	25
Chapter 6 - Theory of Operation.....	26
6.1 Cesium Beam Frequency Standard Concept.....	26
6.2 Cesium Beam Tube.....	28
6.3 Clock Servo.....	32
6.4 Zeeman Servo.....	34
6.5 Gain Servo.....	35

CsIII User Guide

6.6	Microwave Power Servo.....	36
6.7	Unit Initialization.....	37
6.8	Alarms and Indicators.....	38
Appendix A -	Specifications.....	39
A.1	Electrical Specifications.....	39
A.2	Performance Specifications.....	40
A.3	Environmental & Physical Specifications.....	41
Appendix B -	Programmer's Guide.....	43
B.1	General Parameters.....	43
B.2	Restart Message.....	43
B.3	Cesium Command Reference.....	43
Appendix C -	Customer Assistance/Technical Support.....	52
Appendix D -	Declaration of Conformity.....	53

LIST OF FIGURES

Figure 1	CsIII Front Panel.....	4
Figure 2	CsIII Rear Panel.....	4
Figure 3	DC Input and Pin Assignments.....	5
Figure 4	Serial Communication Setup	11
Figure 5	Monitor3 Main Status Window	12
Figure 6	Unit Monitoring Options.....	13
Figure 7	Adjust Output Frequency	15
Figure 8	Synchronize 1 PPS to External Source	15
Figure 9	Slew Output Phase	16
Figure 10	Alarms.....	17
Figure 11	Event Log.....	18
Figure 12	Factory Settings	19
Figure 13	RS-232	20
Figure 14	Typical Hazmat Label Placement	24
Figure 15	Conceptual Diagram of the CsIII.....	26
Figure 16	Block Diagram of the CsIII.....	27
Figure 17	Schematic of the Model 7610 Cesium Beam Tube	28
Figure 18	Behavior of the Cesium ground state sublevels in a magnetic field	30
Figure 19	The complete spectrum of the 7610 CBT	31
Figure 20	Zeeman Frequency, Clock Transition.....	32
Figure 21	CBT Signal & RF Tuning	35
Figure 22	Maximum Signal Level at the Ramsey Interrogation Points	36

LIST OF TABLES

Table 1	Typographical Conventions	2
Table 2	RS-233 Port DB9 to DB25 Connector Pin-out	9
Table 3	RS-232 Port DB9 to DB9 Connector Pin-out	10
Table 4	Interpretation of columns in the Data File created by Unit Monitoring	14
Table 5	Maintenance	21
Table 6	Warm-up Sequence	37
Table 7	Alarm Descriptions, Conditions, and Level.....	38
Table 8	CsIII Command Reference	47
Table 9	Data returned by the “Return Variables” command D*1	49
Table 10	Data returned by the “Return Constants” command D*2.....	51

Chapter 1 - Introduction

This *User Guide* contains information about installing, operating, and maintaining the Symmetricom CsIII Cesium Beam Primary Frequency Standard.

By international agreement, at the 1967 *Conférence Générale des Poids et Mesures*, the *Système Internationale* (SI) unit of time is defined as follows:

“The second is the duration of 9,192,631,770 periods of the radiation corresponding to the transition between the two hyperfine levels of the ground state of the Cesium 133 atom.”

The function of the CsIII is to realize this definition in a continuous and reliable manner, providing the user with convenient output signals with the highest possible stability and accuracy. The CsIII represents the state-of-the-art in Cesium beam technology, both in the design of the physics package as well as the electronic and microprocessor control systems. Comprehensive instrument control and monitoring is provided over the RS-232 interface and the Symmetricom **Monitor3** graphical user interface.

The CsIII is designed for use in laboratory environments for timing and test and measurement applications. The standard output configuration includes one 5 MHz and one 10 MHz sine wave outputs, one 10 MHz TTL and one 1 PPS output. E1 and T1 telecommunications outputs are available as options.

1.1 Who Should Read This User Guide

This *User Guide* is designed for the following categories of users:

Systems Engineers – Chapters **2** and **6** provide an overview of the product, options, and theory of operation. Cross-references in these sections direct readers to detailed system configuration information in Chapter **4**. Chapter **5** provides information about product ordering, shipping, and storage.

Installation Engineers – Chapter **3** provides installation information and procedures. Chapter **4** and **Appendix B** provide specific configuration and operation information to ensure proper operation or, modify the systems configuration.

Maintenance Engineers – Chapter **5** provides preventive and corrective maintenance guidelines. Chapter **6** also provides procedures for diagnosing and troubleshooting fault indications and alarms.

Certain sections, particularly Chapters **1** and **2** are intended for non-technical audiences. Others, such as Chapter **3** through **Appendix A** contain instructions to be performed by qualified personnel only.

1.2 About This User Guide

This *User Guide* is a reference for the CsIII Primary Frequency Standard. It contains an introduction to the CsIII, system and configuration specifications, and procedures for installation, power-up, operation, maintenance, and troubleshooting.

1.3 Typographical and Other Conventions

This *User Guide* uses the following conventions:

Acronyms and Abbreviations – Terms are spelled out the first time they appear this *User Guide*. Thereafter, only the acronym or abbreviation is used. In the glossary defines the acronyms and abbreviations.

Revision Control – The title page lists the part number, revision, and printing date of this *User Guide*. Table 1-1 describes the typographical conventions that this *User* uses to distinguish between the different types of information according to how they are used.

Table 1 Typographical Conventions

When text appears this way...	It means...
<i>Cs III User Guide</i>	The title of a document.
CRITICAL PORT-A J1	An operating mode, alarm state, status, or chassis label.
Press the Enter key.	A named keyboard key as it appears on the keyboard followed by. An explanation of the key's acronym or function immediately follows the first reference to the key, if required.
A <i>re-timing</i> application...	Emphasis on a word or term.
Symmetricom does not recommend...	Special emphasis on a key word or idea.

1.4 Warnings, Cautions, Recommendations, and Notes

Warnings, Cautions, Recommendations, and Notes attract attention to essential or critical information in this *User Guide*. The types of information included in each are explained as follows:

WARNING...

Do not disregard warnings. They are installation operation, or maintenance procedures, practices, or statements that, if not strictly observed, may result in personal injury, loss of life, or equipment damage.

ELECTRICAL SHOCK HAZARD...

All electrical shock hazard warnings have this symbol. To avoid serious personal injury or death, do not disregard electrical shock warnings. They are installation, operation, or maintenance procedures, practices, or statements that, if not strictly observed, may result in personal injury or

loss of life.

CAUTION...

Do not disregard cautions. They are installation, operation, or maintenance procedures, practices, conditions, or statements that, if not strictly observed, may result in damage to or destruction of equipment or may cause a long-term health hazard.

CAUTION...

They are installation, operation, or maintenance procedures, practices, conditions, or statements, that if not strictly observed, may result in electrostatic discharge damage to, or destruction of, static-sensitive components of the equipment.

RECOMMENDATION...

Recommendations indicate manufacturer-tested methods or known functionality. They contain installation, operation, or maintenance procedures, practices, conditions, or statements that provide important information for achieving optimal results.

NOTE...

Notes contain installation, operation, or maintenance procedures, practices, conditions, or statements that alert you to important information that can make your task easier or increase your understanding.

Chapter 2 - Product Overview

The Symmetricom CsIII Cesium Beam Frequency Standard is designed for high precision timing and frequency applications requiring high stability, low noise RF and 1 PPS reference signals.

The CsIII comes in a standard 19-inch wide rack mount housing. It is 2U high (3.75”) and weighs 28 lbs (12.7 kg). Refer to **Appendix A – Specifications** on page 39 for detailed performance specifications.



Figure 1 CsIII Front Panel



Figure 2 CsIII Rear Panel

2.1 LED Indicators

The following indicators are available on both the front and the rear panel.

- **Power Indicator** – Green LED indicates power applied to instrument
- **Lock Indicator** – Green LED indicates normal operation
- **Alarm Indicator** – Red LED indicates unit alarm condition

2.2 Rear Panel Connections

- **5 MHz** – BNC 5 MHz output (50Ω)
- **10 MHz** – BNC 10 MHz output (50Ω)
- **10 MHz TTL** – BNC 10 MHz TTL output (50Ω)
- **1 PPS** – BNC 1 PPS output (50Ω)
- **SYNC** – BNC input to synchronize 1 PPS output to external source (50Ω)
- **ALARM** – DB9 Female, Form C relay
- **RS-232** – DB9 Male DTE

2.3 Software

The CsIII's principal user interface is the Symmetricom **Monitor3** software. **Monitor3** runs on PCs running the Microsoft Windows (Windows 95 or newer) and connects to the CsIII with a standard RS-232 null modem cable. In addition to providing comprehensive configuration and control of the CsIII, **Monitor3** provides periodic monitoring of the instrument's state-of-health parameters and, optionally, logs data to disk for subsequent analysis. **Monitor3** also provides logging of Alarm events to a log file for monitoring and troubleshooting purposes. **Monitor3** is not essential to operate the CsIII if there is no need to modify factory default parameters, adjust frequency or phase of outputs, or to monitor internal health parameters. In some applications, users may develop their own interface software for control and monitoring of the CsIII. The RS-232 command structure and command list are documented in **Appendix B – Programmer's Guide**.

2.4 Power

External power is supplied by a standard AC power cord or by a DC power connection. The power hierarchy is as follows:

- If AC power is available, the unit operates from the AC power.
- If AC power is NOT available and DC power is, the unit operates from the DC input.
- If both AC and DC are applied, the CsIII operates the input with the higher voltage.

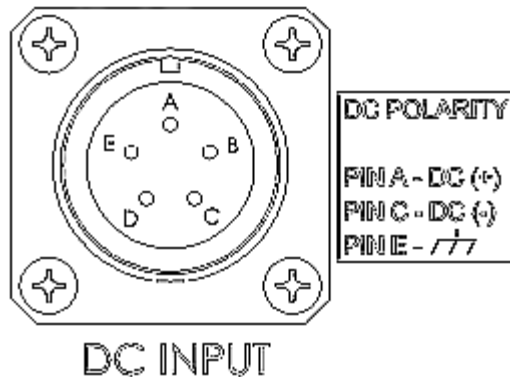

Figure 3 DC Input and Pin Assignments

2.5 Factory Configurations

The **CsIII** is available with optional features that permit the system designer to specify the most cost-effective solution for a particular application. Optional features include:

- E1 or T1 telecommunication outputs.
- Portability kit

Chapter 3 - Installing the CsIII

This section provides unpacking instructions and installation procedures for the CsIII as well as warnings, cautions, notes, and recommendations that pertain to the procedures being performed. To prevent serious injury and/or equipment damage, do not ignore these safety, environmental, and operational messages.

NOTE...

If you encounter problems during any of the following procedures, contact Technical Support (see page 52).

3.1 Unpacking Instructions

CAUTION...

To avoid electrostatic discharge (ESD) damage to sensitive internal parts, observe proper ESD handling procedures.

1. Inspect the container for signs of damage. If the container appears to be damaged, notify both the carrier and the Symmetricom distributor. Retain the shipping container and packing material for the carrier to inspect.
2. Unpack all components in the shipping container.
3. Inventory, and set aside all items and paperwork that are included in the container.
4. Verify that the model and item number shown on the shipping list agrees with the model and item number on the equipment. The item number can be found on a label affixed to the rear panel. Contact the Symmetricom distributor if the model or item numbers do not match

CAUTION...

This instrument must be operating only as specified by the manufacturer. Use other than as specified may compromise the safety precautions of the system.

3.2 Environmental Considerations

When installing the instrument, consider the standard environmental factors (temperature, humidity, vibration, etc.) and the presence of magnetic fields that might affect the accuracy of the CsIII. Avoid installing or using the instrument near large motors, generators, transformers, and other equipment that radiates strong AC or DC fields of 2-gauss or more.

3.3 Pre-Installation Checklist

Before installation, ensure that the following preparations are in place:

- The equipment rack is grounded and has power available
- Sufficient space is available in the equipment rack to accommodate the 2U CsIII as well as an additional 1U of space above and below the CsIII
- Chassis rack supports or slides are available to support the CsIII

3.4 Tools and Materials

The following is a list of recommended tools and materials **NOT** supplied:

- Standard tool kit
- Rack supports or slide mounts
- Personal computer running Windows 95 or newer with one available serial port
- Null modem cable

3.5 Installing the CsIII

The CsIII mounts in a standard 19-inch equipment rack. The CsIII side plates are drilled and tapped to accept chassis rack slides. The use of chassis rack slides or other means of support is necessary because of the weight and weight distribution of the instrument. The front panel occupies a height of 3.75" (2U).

CAUTION...

To avoid damage to the system, access covers must not be removed, except by trained service personnel.

WARNING...

For continued protection against risk of fire, ensure that only the specified fuse type and rating are used. Fuse specifications are provided on page 41 and on the instrument's rear panel.

CAUTION...

To prevent damage to the instrument during installation, disconnect the power by removing the fuse from the rear panel. The fuse is the emergency disconnect for the device – there is no ON/OFF switch.

CAUTION...

The instrument is convection cooled. To prevent the instrument from overheating, leave one rack unit (1.75 in./4.44 cm) space above the unit for cooling.

CAUTION...

To avoid electrostatic discharge (ESD) damage to components inside the instrument, observe proper ESD handling procedures.

1. Mount the CsIII in the desired location in the equipment rack using standard rack mount hardware.
2. Install the proper fuse into the fuse holder marked **DC Fuse** on the rear panel. Fuse specifications are provided on page 41 and on the instrument's rear panel.
3. If available, apply AC power to the CsIII by installing the detachable power supply cord at the AC Input connection on the rear panel.
4. If available, apply DC power to **DC Input** (see page 41 for pin out information).
5. Observe that the **POWER** and **ALARM** front panel indicators are illuminated. Wait for the unit to stabilize and complete its initial acquisition sequence. This may take up to 30 minutes. When stabilized, the **ALARM** indicator turns off and the **LOCK** indicator illuminates. The **ALARM** relay is reset and all signal outputs are activated.

NOTE...

Applying the power to the instrument initiates the warm-up and automatic lock acquisition sequence. During this time, the **ALARM** relay is activated and the signal outputs are not active.

3.6 Installing the Monitor3 Software

The **Monitor3** software runs on any PC or laptop running Microsoft Windows 95 or newer. It requires less than 1 MB of disk space and one available serial (COM) port to connect to the CsIII.

1. Locate the Monitor3 software on the CD-ROM provided in the shipping container. If unable to locate the CD-ROM, contact Customer Service (page 52) for a replacement CD-ROM.
2. Install the CD-ROM into the computer
3. Run the program setup.exe located on the CD-ROM by clicking the Start button, selecting **Run...**, and from the command line typing x:\setup.exe, where x is the drive letter of the installed CD-ROM.

This installs the Monitor3 application on your computer in, by default, the c:\Program Files\Symmetricom directory. A folder, named "Symmetricom" is added to your Start menu containing an icon for the Monitor3 application. An uninstall icon is also added so that you can easily remove the program in the future.

Table 2 RS-233 Port DB9 to DB25 Connector Pin-out

DB9-F	DB25-F	Function
3	3	RX (Receive Data)
2	2	TX (Transmit Data)
5	7	GND (Signal Ground)

If you have a DB9 connector on your computer, refer to the following table for connector pin-out information.

Table 3 RS-232 Port DB9 to DB9 Connector Pin-out

DB9-F	DB9-F	Function
3	2	RX (Receive Data)
2	3	TX (Transmit Data)
5	7	GND (Signal Ground)

3.7 Establishing Communications

Connect the serial port of the computer to the RS-232 port of the CsIII using a standard RS-232 null modem cable.

Click the Start button; select Programs->Symmetricom->Monitor3. The Monitor3 interface appears as shown in Figure 5.

The CsIII's default RS-232 settings are as follows:

- 9600
- Data bits = 7
- Parity = Odd
- Stop Bits = 2

To reconfigure these settings on the CsIII, see “RS-232 System Interface and Control” on page 40. By default, Monitor3 will initially attempt to connect to the instrument using these parameters and PC serial port COM1. To check or adjust these communication parameters, select Configure Serial Port... from the File menu. The panel shown in Figure 4 appears. Use this panel to adjust the Monitor3 serial communications parameters to agree with the setting of the CsIII instrument.

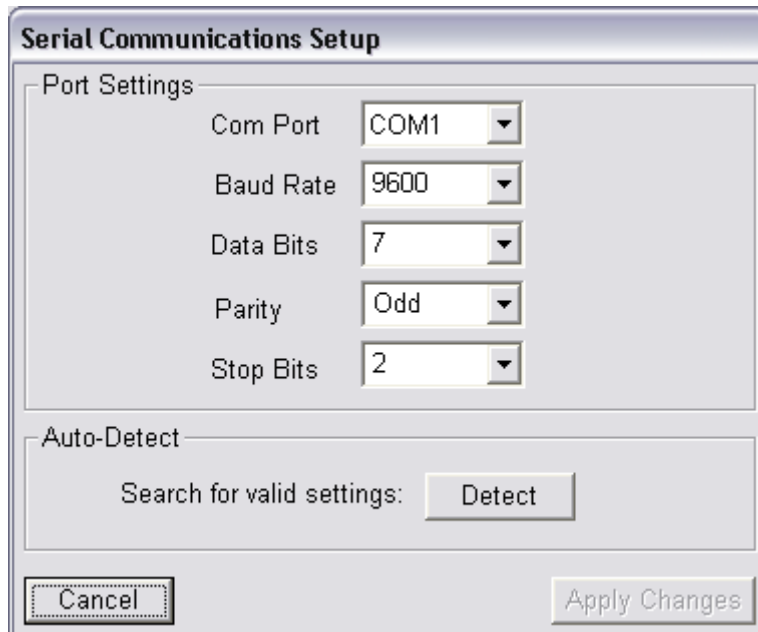

Figure 4 Serial Communication Setup

The modified settings are applied when the Apply Changes button is depressed, at which time Monitor3 will reset the serial port and attempt to reestablish communications with the Cesium instrument. After communications have been successfully established, the communications parameters of the CsIII can be modified see “RS-232 System Interface and Control” on page 40.

In the event of communications problems, the Detect button may be employed to sequentially test the interface at a variety of communications parameters and locate the instrument.

By default, Monitor3 will interrogate the CsIII and update the screen information every ten seconds. The status bar, in the lower left of the main window, which reports countdown to the next update and communications activity as it occurs, indicates RS-232 status. In the event of communications failure, the status bar will indicate Unit Not Responding. In the case, Monitor3 will periodically reinitialize the communications port and attempt to establish communications.

When communications have been successfully established, the Monitor3 interface appears as shown in Figure 5, below. The title bar of the Monitor3 application window will reflect the instrument type (here, CsIII), the serial number (here 6172), and the PC RS-232 interface (here, COM2). Instrument state is indicated in the lower right status bar (here, Operating). By default, the displayed data updates every 10 seconds. The RS-232 status bar, on the lower left, indicates countdown to the next update and RS-232 activity as it occurs.

Chapter 4 - Operation

Prior to performing any of the operations described in this section, ensure that the installation procedures described in “Chapter 3 – Installing the CsIII” have been performed and that communications have been established between the CsIII and the **Monitor3** application software.

In some installations, users may develop custom application software to provide remote control and monitoring capability. Please refer to **Appendix B – Programmer’s Guide** for details of command syntax and the complete command reference.

4.1 Monitor3 Main Status Window

Figure 5 shows the **Monitor3** main status window under normal operating conditions. The title bar of the main window indicates the Cesium instrument model, serial number, and PC communications port. The status bar at the bottom of the main window indicates RS-232 communications activity on the left and instrument status (**Warming Up**, **Operating**, **Minor Fault**, or **Major Fault**) on the right.

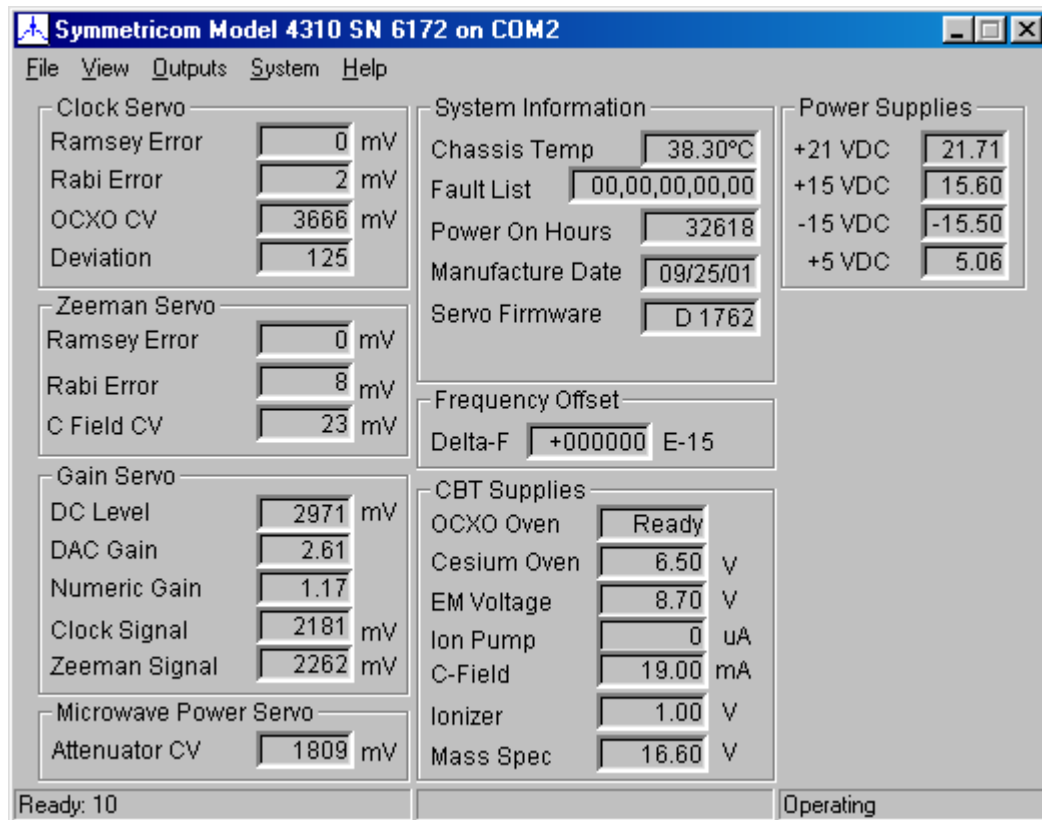

Figure 5 Monitor3 Main Status Window

The body of the main window displays operating and configuration data for the **CsIII** instrument. The main window updates periodically (see **Unit Monitoring**, below). The

left-hand column reflects parameters associated with the digital operating servos, including the main **Clock Servo**, the C-Field or **Zeeman servo**, the **Gain Servo**, and the **Microwave Power Servo**. The middle column contains the **System Information**, user programmed **Frequency Offset**, and monitors of the **Cesium Beam Tube Power Supplies**. The right hand column displays monitors of the internal **Power Supplies**. The definitions, interpretation, and normal values of the displayed data are discussed in the following sections as well as in Appendix B -Programmer's Guide.

4.2 Unit Monitoring and Data Logging

In order to adjust the polling rate and/or enable logging of data to disk, select **Configure Unit Monitoring** from the **File** menu.

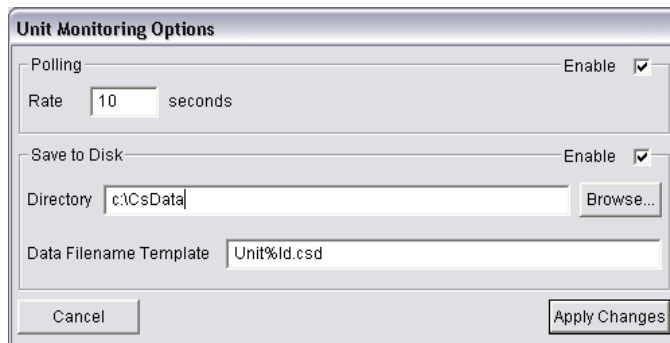

Figure 6 Unit Monitoring Options

From the **Unit Monitoring** panel, shown above, enable or disable monitoring with the **Enable Monitoring** checkbox and adjust the polling rate by typing a value into the **Polling Rate** edit box.

In order to save the monitor data to the PC's hard disk for archive or subsequent analysis, enable the **Create Data File** checkbox. The data will be saved at each polling interval in the **Output Directory** specified. The output directory can be changed either by typing a new directory name into the **Output Directory** field or by activating the **Browse...** panel and selecting a new directory from the tree displayed therein. Note that the data will not be saved if the specified directory does not exist.

The name for the data file may be entered into the **Data Filename Template** field. The macro field “%ld” is replaced with the serial number of the **CsIII** instrument when the file is created. In our example, the saved data would appear in the file:
c:\Unit6172_Data.csv.

The saved data file contains 52 comma-delimited columns. The first row of the file contains the column headings, which correspond with the data displayed by **Monitor3** as identified in Table 4, below. Note that the values displayed in the “**Typical**” column of Table 4, below, correspond to those in Figure 5, above.

Table 4 Interpretation of columns in the Data File created by Unit Monitoring

Col	Heading	Description	Typical	Range	Units
1	MJD	Fractional Days since 0hr November 17, 1858. Measured by PC clock	52991.8122		days
2	ID	Serial Number of Unit	6172	0-99999	
3	UnitType	Model Identifier	400	400-410	
4	Factory	Data Taken at factory	0	0, 1	
5	State	Instrument state	00	00: Operating 01: Warm-up 10: Minor Alarm 11: Major Alarm	
6	Alarm1	First element of prevailing alarm list	00	00-FF	
7	Alarm2	Second element of prevailing alarm list	00	00-FF	
8	Alarm3	Third element of prevailing alarm list	00	00-FF	
9	Alarm4	Fourth element of prevailing alarm list	00	00-FF	
10	Alarm5	Fifth element of prevailing alarm list	00	00-FF	
11	StdDev	Signal Standard Deviation	125	100-200 (SP) 50-100 (EP)	mV
12	CRamErr	Clock Transition Ramsey Error	0	+/- 9999	mV
13	CRabErr	Clock Transition Rabi Error	2	+/- 9999	mV
14	CLevel	Clock Transition Signal Level	2181	0-9999	mV
15	VVCXO	VCXO Control Voltage	3666	0-5000	mV
16	ZRamErr	Zeeman Transition Ramsey Error	0	+/- 9999	mV
17	ZRabErr	Zeeman Transition Rabi Error	8	+/- 9999	mV
18	ZLevel	Zeeman Transition Signal Level	2262	0-9999	mV
19	VCField	C-Field Control Voltage	23	+/- 2500	mV
20	ICField	C-Field Current	19.0	17-21	mA
21	VuWave	Microwave Power Control	1809	0-5000	mV
22	DCLevel	DC Signal Level	2971	0-5000	mV
23	DACGain	Digital Preamplifier Gain	2.61	0-255	
24	NumGain	Numerical Gain	1.17	0.1-9999	
25	TChasis	Chassis Temperature	38.3	0-99	°C
26	VcsOven	Cesium Oven Heater Voltage	6.5	0-15	V
27	OscState	OCXO Oven State	Ready	“Cold” or “Ready”	
28	VEM	Electron Multiplier Control Voltage	8.7	5-10	V
29	IIP	Ion Pump Current	0	0-10	μA
30	VMS	Mass Spectrometer Bias Voltage	16.6	12-18	V
31	VION	Ionizer Voltage Drop	1.0	0.5-1.5	V
32	OCXOTau	Clock OCXO Loop Time Constant	1.0	0.1-99.9	sec
33	FreqTune	User Frequency Offset	+000000	+/- 999999	x10 ⁻¹⁵
34	Pos24V	21 VDC Secondary Supply	21.71	0-99.99	V
35	Pos5V	5 VDC Secondary Supply	5.06	0-99.99	V
36	Pos15V	+15 VDC Secondary Supply	15.6	0-99.99	V
37	Neg15V	-15 VDC Secondary Supply	-15.5	-99.99-0	V
38	Version	Cesium module Firmware Version	D 1762		

4.3 Adjusting Output Frequencies

The output frequency of the **CsIII** may be adjusted by $\bar{y} = \pm 1 \times 10^{-9}$ with a resolution of 1 part in 10^{15} . This is generally used for calibration purposes and is accomplished by directly modifying the fundamental interrogation frequencies of the physics package and is thereby reflected on all outputs. In order to modify the programmed offset frequency, select **Delta-F...** from the **Outputs** menu.

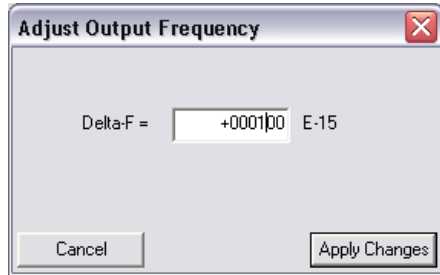

Figure 7 Adjust Output Frequency

The **Adjust Output Frequency** panel appears, as shown above, reflecting the current programmed offset of the **CsIII**, in this case $\bar{y} = +1 \times 10^{-13}$. To change the offset frequency, enter a new value, between -999999 and $+999999$, into the edit field and click the **Apply Changes** button to upload the correction to the **CsIII**. To exit the **Adjust Output Frequency** panel without applying changes, select **Cancel**. The updated output adjustment will be reflected in the **Frequency Offset** field following the next RS-232 update of the displayed data.

4.4 Synchronizing to a 1 PPS Source

The 1 PPS output of the **CsIII** is generated by direct division of the 10 MHz RF output and, as such, reflects the phase of one particular cycle of the 10 MHz. In order to synchronize the 1 PPS output to an external user-supplied 1 PPS source, with 100 nS resolution, connect the 1 PPS source to the back-panel **1 PPS Sync** input and select **Synchronize 1 PPS...** from the **Outputs** menu. The panel appears as shown below.

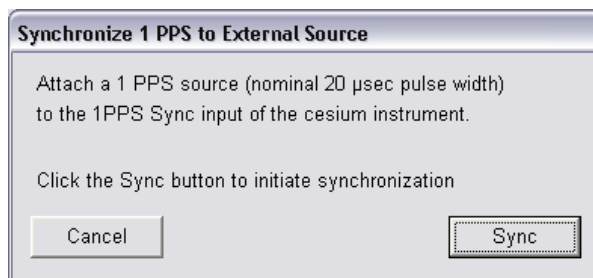

Figure 8 Synchronize 1 PPS to External Source

The **CsIII** will synchronize its 1 PPS outputs to within +/- 100 nS of the applied external 1 PPS source if a rising edge is detected within 3 seconds after pressing the **Sync** button. Select **Cancel** to exit the panel without re-synchronizing the 1 PPS output.

4.5 Slewing the Output Phase

In order to provide finer resolution adjustment of the output phase then is available from the **1 PPS Synchronization** feature, the output phase can be slewed, with 1 nS resolution, using the **Delta-T** function. This function is implemented by deliberately offsetting the output frequency of the **CsIII** by either $\bar{y} = +1 \times 10^{-9}$ or $\bar{y} = -1 \times 10^{-9}$ for N seconds, thereby introducing a phase offset of plus or minus N nS, respectively. Note that, unlike the **1 PPS Synchronization** feature, the **Delta-T** function affects the phase on all outputs, including RF and 1 PPS.

Note also that the output frequency of the instrument is significantly perturbed, by $\bar{y} = \pm 1 \times 10^{-9}$, for the duration of the adjustment. For example, phase advance of 1 mS, will introduce a $\bar{y} = +1 \times 10^{-9}$ error in all clock outputs, persisting for 10^6 seconds, almost 12 days! In order to avoid introducing an offset for such a long duration, it is recommended to use the **Sync 1PPS** feature (see above) to bring the phase to within 100 ns of the desired value.

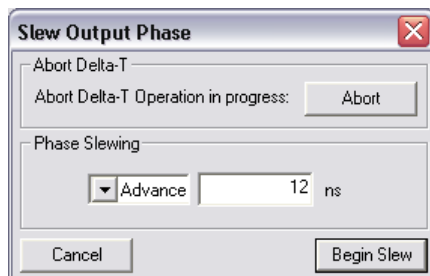

Figure 9 Slew Output Phase

In order to adjust the output phase, select **Delta-T...** from the **Outputs** menu. The **Slew Output Phase** panel appears. Enter the desired output phase, in the range of 0- nS and select either **Advance** or **Retard** from the pull down menu. Press **Begin Slew** to begin the phase slewing operation. The output frequency of the **CSIII** will immediately be offset by either $\bar{y} = +1 \times 10^{-9}$ or $\bar{y} = -1 \times 10^{-9}$, depending on whether you've selected **Advance** or **Retard**, respectively. If you wish to abort the phase slewing operation in process, and return the instrument to its nominal frequency, return to the **Slew Output Phase** panel and press the **Abort** button at any time during the operation.

4.6 Alarms

The **CsIII** microprocessor system provides continuous monitoring of system power supplies, signal quality, and numerous physics package operating parameters, as indicated on the **Monitor3** main panel. Alarms are generated in the event that any of several parameters deviates from its acceptable value.

Alarms are classified into two types:

- **Minor Alarm** – indicates out of nominal specification that should be noted but is not expected to impact instrument performance.
- **Major Alarm** – indicates detection of a fault that will cause the instrument to fail to meet specification.

In the event of **Minor Alarm**, the **ALARM** LED illuminates on the instrument front panel, in addition to the **POWER** and **LOCK** LEDs. All outputs remain active and the **ALARM** LED remains illuminated for as long as the alarm condition persists.

In the event of **Major Alarm**, the **LOCK** LED turns off and the **ALARM** LED illuminates. All outputs are disabled. If the alarm condition ceases, the instrument restarts from its initial power-on condition. The current list of alarms is indicated, by hexadecimal code in the alarm list on the **Monitor3** main panel. To see an annotated list of alarms, clear alarms, or set the priority of the restart alarm, select **Alarms...** from the **System** menu.

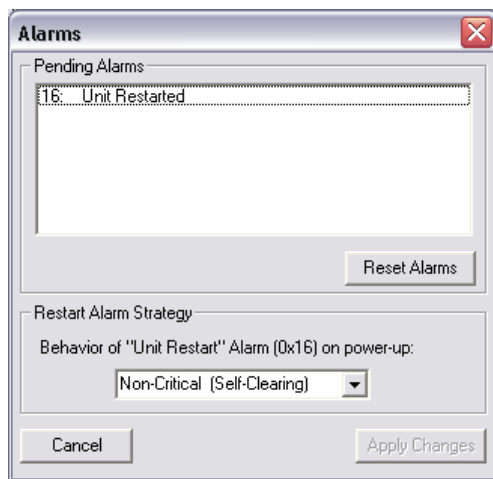

Figure 10 Alarms

The **Alarms** panel, shown above, enumerates all alarms currently present in the system. In order to clear standing alarms, press the **Reset Alarms** button. The list of pending alarms will be updated at the next regular polling interval. For a complete list of possible alarms, see **Chapter 5 – Maintenance & Troubleshooting**.

There are two possible alarm strategies in the event of unit restart, which may be selected from the **Restart Alarm Strategy** pull-down menu and uploaded to the CsIII by pressing the **Apply Changes** button. These are:

- **Non-Critical** (Default) - In the event of restart, the 0x16 alarm flag is set, outputs are muted during re-acquisition and restored upon successful lock. The 0x16 alarm flag remains set until cleared by the user.
- **Critical** – In the event of restart, the 0x16 flag is set, outputs are muted during re-acquisition and remain muted thereafter until the user clears the 0x16 alarm flag.

4.7 Event Logging

The CsIII maintains a log of alarm indicators, including major and minor alarms as well as unit restart events. The Event Log is maintained in battery-backed non-volatile in order to retain persistence through power cycles to enable forensic debugging in event of unit failure. Logged events include the activation of an alarm as well as the subsequent clearing of an alarm, whether automatically, due to the removal of the alarm condition, or due to user interaction.

To access the **Event Log**, select **Event Log** from **Monitor3's View** menu.

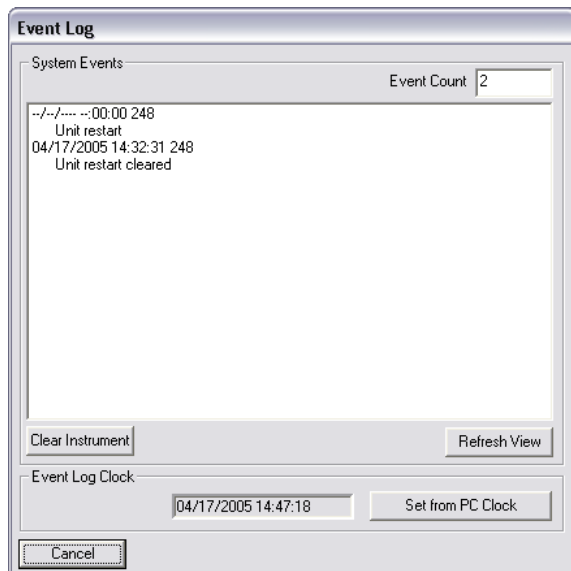

Figure 11 Event Log

The Event Log is downloaded from the CFS when the **Event Log** panel is loaded or when the user clicks the **Refresh View** button. Note that downloading the Event Log from the CFS can take up to several minutes, depending on the number of events and the connection speed. Because of this necessary delay, the Event Log display panel is not automatically updated once initially displayed.

All events are identified by a time tag, indicating the time of the appearance or disappearance of the alarm condition. The time tag is composed of the date and time, as realized by the CFS event log clock and the total number of operating hours on the instrument (248 in the example above). Because the Event Log clock is restarted upon power failure, the **Unit Restart** events necessarily occur at time --/--/---- --:00:00, as shown in the example above. Once the Event Log clock has been set, subsequent events are time tagged appropriately. To set the Event Log clock to the time on your PC, click **Set from PC Clock**.

The non-volatile Event Log storage contains 128 events. Once the log is fully populated subsequent events are discarded. For this reason, it is useful to periodically check and clear the Event Log, particularly in installations where the power to the instrument is frequently cycled, thus producing numerous **Unit Restart** events. To clear the non-volatile Event Log in the CFS, press the **Clear Instrument** button. In permanent installations, Symmetricom recommends clearing the **Event Log** and setting the **Event Log Clock** upon installation.

4.8 Factory Settings

There are several settings available from the **Factory Settings...** panel on the **System** menu. Generally, these settings should not be modified, except by trained personnel, but are included in the **Monitor3** interface in order to accommodate particular applications.

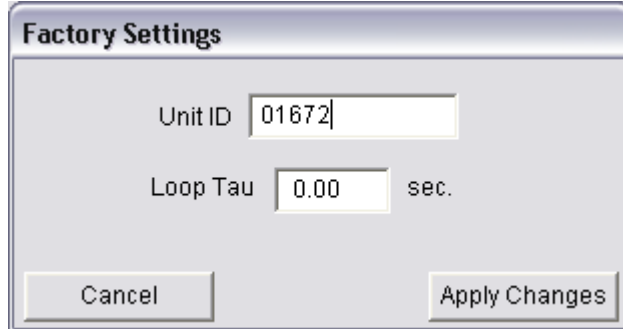

Figure 12 Factory Settings

The **Unit ID** is a 5-digit number, set in the factory to reflect the last 5 digits of the serial number of the instrument, as printed on the back panel label. To change the **Unit ID**, enter a new 5-digit value in the edit field and press the **Apply Changes** button.

The **Loop Tau** is the fundamental time constant of the OCXO servo. The factory default value of $\tau = 1.0$ second is appropriate for most applications. Operation at other values of τ may compromise instrument performance. A complete discussion of the trade-offs inherent to selecting the **Loop Tau** is beyond the scope of this manual and this value should not be changed, except by knowledgeable personnel. To change the **Loop Tau**, enter a new value, between 0.1 and 99.9 seconds, in the edit field and press the **Apply Changes** button.

4.9 Communications

Upon delivery, the CsIII communicates with the following serial interface parameters:

- Baud = 9600
- Data bits = 7
- Parity = Odd
- Stop Bits = 2

In order to accommodate particular specialized installations, the RS-232 communications parameters of the CsIII instrument may be adjusted from the **RS-232...** panel on the **System** menu.

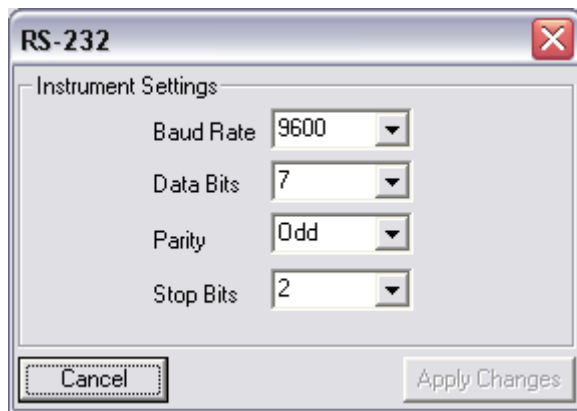

Figure 13 RS-232

To change the communications settings, select the desired settings from the pull-down menus and click on the **Apply Changes** button to upload the new settings to the **CsIII**. After commanding the CsIII to alter its settings, **Monitor3** modifies its own communications parameters to the new CsIII settings and reestablishes communications with the new settings. Note that no settings are applied until the **Apply Changes** button is clicked. To exit the panel, retaining the previous settings, select **Cancel**.

Chapter 5 - Maintenance & Troubleshooting

This section provides information about preventive maintenance, re-ordering parts, accessories, and re-shipment of product.

CAUTION...

- To avoid electrostatic discharge (ESD) damage to sensitive internal parts, observe proper ESD handling procedures.
- Never attempt to clean the interior of the instrument with a vacuum.

CAUTION...

To avoid damage, don't allow the interior of the instrument to come into contact with water under any circumstances.

NOTE...

- If you encounter problems during any of the following procedures, contact Technical Support (see page 52).
- Save the instrument's original packing materials for re-shipping the product. If these are not available, please contact Technical Support for a replacement.

5.1 Preventive Maintenance

The CsIII unit requires minimum preventive maintenance. Care should be taken to insure the unit is not exposed to hazards such as direct sunlight, open windows, or extreme heat. Should the unit require cleaning, the exterior chassis may be wiped off using a soft cloth dampened with mild soapy water.

Table 5 lists suggested preventive maintenance measures to be performed at periodically at the user's discretion, as time permits. These procedures are not required. Do not disassemble components solely for the purpose of inspection. During a component disconnection procedure, such as a cable removal or replacement, inspect components according to the inspection procedures.

Table 5 Maintenance

Item	Inspection	Corrective Action
Unit Case	Inspect for dirt or foreign material.	Clean the exterior of shelf with a soft dry cloth.
Cables	Inspect for pinched, worn, or damaged cable.	Replace at first opportunity.
Connectors	Inspect for loose or damaged connectors and jacks, bent or missing pins.	Tighten loose connectors. If damaged, replace at the first opportunity.
Power Fuse	Inspect for loose or damaged holder.	Contact Symmetricom Technical Support (see page 52)
Case Screws	Inspect for loose or missing screws or hardware on shelf.	If loose, tighten securely. Replace missing hardware.

5.2 Troubleshooting

If the alarm activates and the ALARM LED remains lit indicating a failure of the CsIII, call Symmetricom Customer Service for instructions. Table 7 on page 38 lists the two-digit hexadecimal fault codes along with their description. Prior to calling Customer Service, please take note of the instrument model and serial numbers, any installed options, and the complete list of persistent alarm codes, available from the **Alarms...** panel on the **Monitor3 System** menu.

The complete list of possible alarm conditions is shown in **Section 6.7**.

5.3 Shipping

To turn off the Symmetricom CsIII prior to shipment, remove the power. Remove all external connections and remove the unit from the rack or cabinet. Place the unit in its HAZMAT shipping container.

5.3.1. Hazardous Material (HAZMAT) Shipping Considerations

Symmetricom Cesium standards contain a small amount of Cesium metal. The Cesium isotope used (Cesium 133) is non-radioactive. However, because of its reactive chemical properties, Cesium is classified as a hazardous material by the U.S. Department of Transportation (USDOT) and the International Air Transport Association (IATA). During normal handling the Symmetricom CsIII presents no danger since the Cesium is encased within a vacuum-sealed metal enclosure. Hazardous materials, depending upon their specific nature, are subject to certain shipping regulations of the USDOT and the IATA. These regulations govern the shipping case as well as its labeling.

The initial shipment of every Symmetricom Cesium standard complies with HAZMAT regulations by using a shipping case that has been tested and certified. This case has been designed to prevent damage to the unit during shipment and to meet current hazardous-material shipping regulations. The case can be used repeatedly and should be retained for any future shipping requirements of the instrument. In addition, the following required labels have been placed on the case:

- FRAGILE
- DANGEROUS WHEN WET
- DANGER – NO PASSENGER AIRCRAFT
- CESIUM UN 1407

5.3.2. Shipping Products Back to the Factory

Return all units in the original packaging. After the standard packing procedure to protect the equipment, Cesium products being returned for repair require special preparation for shipment as described in “Shipping Carriers” on page 23. Connectors

should be protected with connector covers or the equipment should be wrapped in plastic before packaging. Take special care to protect the front and rear panels.

To return equipment to the factory or local representative for repair:

- 1) Call Customer Service at 1-512-721-4000 to obtain a return material authorization (RMA) number before returning the product for service.
- 2) Provide a description of the problem, product item number, serial number, and warranty expiration date.
- 3) Provide the return shipping information (customer field contact, address, telephone number, and so forth).
- 4) Pack all items into the original shipping container.
- 5) Ensure the container is properly marked as described in “Shipping Carriers” on page 40.
- 6) Ship the product to Symmetricom, transportation prepaid and insured, with the RMA number and serial numbers clearly marked on the outside of the container to:

Symmetricom, Inc. Attn: Service Dept.
34 Tozer Road
Beverly, Massachusetts 01915
USA
Tel: +1 978 927 8220
Fax: +1 978 927 4099

5.3.3. Shipping Carriers

The shipper is responsible for the overall condition of the Hazardous Material shipping case; such as latches locked (if applicable), no visible damage to case and the proper placement of all labels on the case. Figure 14 illustrates the proper placement of labels. Make sure an address label, proper HAZMAT labels, and packing slip (if necessary) are affixed to the shipping case and are clearly visible.

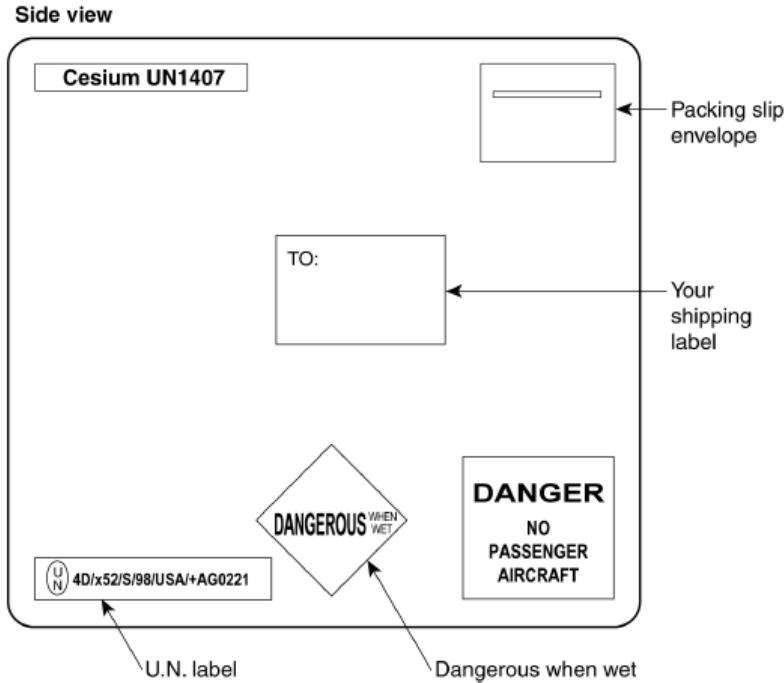

Figure 14 Typical Hazmat Label Placement

Several United States and international shipping companies can accommodate properly packaged hazardous materials. United Parcel Service and Federal Express are examples for the United States. Intercontinental (617-569-4400) provides international shipping services. Contact one of these shipping companies for assistance. If you need additional help, call Symmetricon Technical Service at **512-721-4000**.

Freight carriers typically request the following information:

- Proper Shipping Name: Caesium (Cesium) Dangerous When Wet
- Class Or Division: 4.3 UN or ID No.: UN1407
- Type Of Packing: One Fiberboard Box x5 Grams
- Packing Instructions: 412

5.4 Storage

During storage of the CsIII, there are two factors to consider: Cesium beam tube vacuum and shelf life.

5.4.1. Cesium Beam Tube Vacuum

If the CsIII is stored for extended periods of time (>6 months), the unit should be powered on for a minimum of 30 minutes every six months in order to maintain the tube vacuum. The CsIII must be turned-on and operated for a minimum of 30 minutes on or before the first six-month storage interval.

5.4.2. Cesium Beam Tube Shelf Life

Extended high temperature storage (>50°C) reduces the expected operating life of the Cesium beam tube. The reduction in tube life expectancy is approximately 4 months for each year of storage at 70°C.

Chapter 6 - Theory of Operation

This section provides the theory of operation of the CsIII Cesium beam frequency standard. It is intended to supplement the functional description provided in earlier chapters and provide a more complete understanding of instrument operation.

6.1 Cesium Beam Frequency Standard Concept

As described in **Chapter 1 – Introduction**, the SI unit of time is defined as follows:

“The second is the duration of 9,192,631,770 periods of the radiation corresponding to the transition between the two hyperfine levels of the ground state of the Cesium 133 atom.”

Figure 15, below, shows a conceptual diagram of the CsIII.

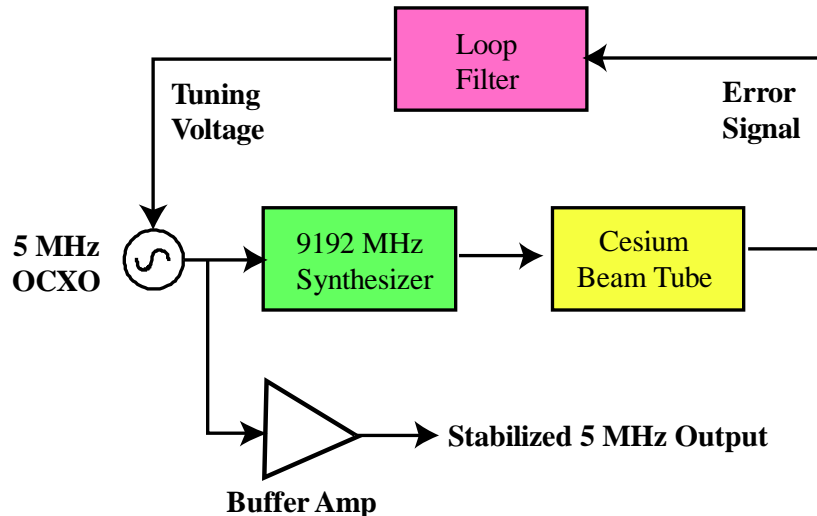

Figure 15 Conceptual Diagram of the CsIII

The fundamental accuracy and stability of the CsIII are derived from its “physics package” or “Cesium beam tube,” whose function is to provide a near-ideal environment for continuously measuring the Cesium hyperfine transition. All outputs of the CsIII are derived from an ovenized low phase noise 5 MHz quartz oscillator, whose output frequency is converted up to 9,192,631,770 Hz and applied to the Cesium beam tube (CBT). The CBT produces an error signal, whose sign and amplitude reflect the detuning of the quartz oscillator with respect to the definition of time. In normal operation, the synthesizer, under microprocessor control, provides optimal interrogation of the Cesium resonance, periodically hopping between interrogation points located on either side of the principal Cesium resonance. The microprocessor-based “Loop Filter” or “Servo” continuously demodulates and integrates the error signal and adjusts the oscillator tuning voltage of the oscillator so as to null the integrated error signal, thereby guaranteeing the long-term stability and accuracy of the 5 MHz output frequency. For measurement

intervals that are short compared to the time constant of the loop filter, which is typically on the order of $\tau = 1$ second, the output signal characteristics, phase noise and stability, are determined by the properties of the quartz oscillator. At longer times, the output signals reflect the properties of the CBT.

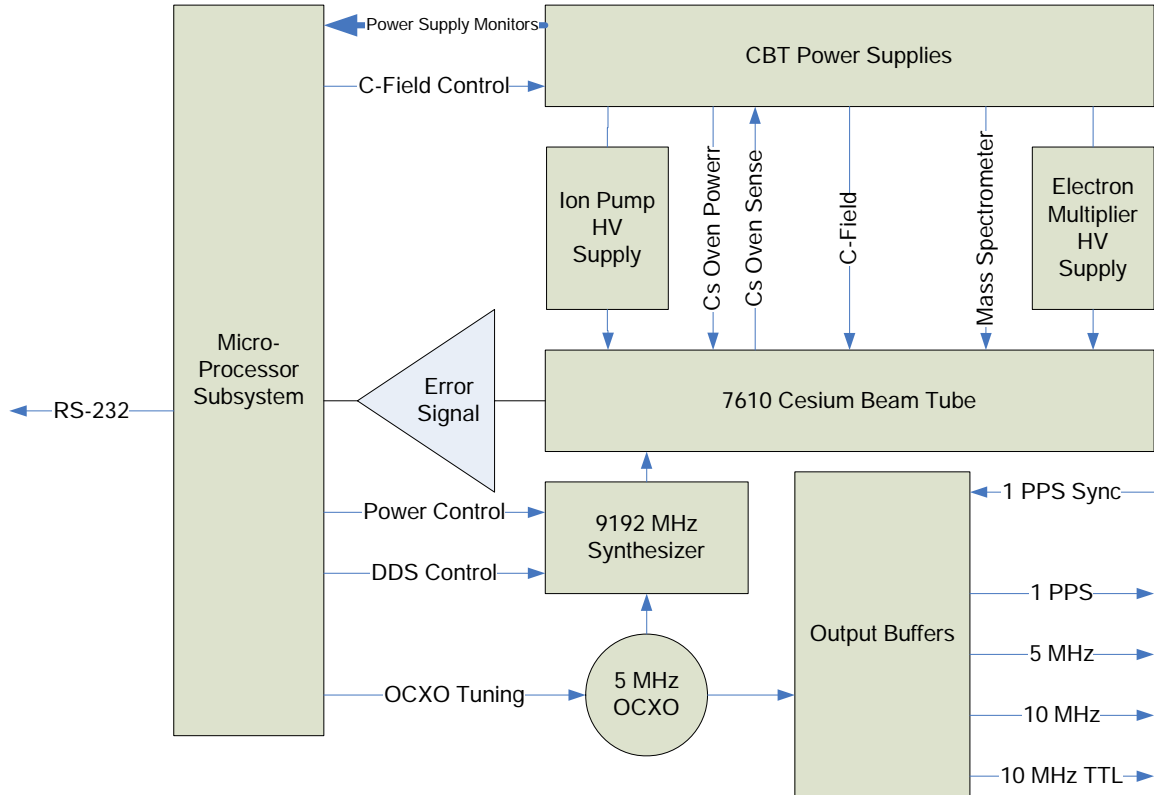

Figure 16 Block Diagram of the CsIII

Figure 16, above, shows a block diagram of the **CsIII**. The principal components of the **CsIII** include:

- A 5 MHz ovenized quartz oscillator that provides the reference for all outputs.
- An RF synthesizer that converts the 5 MHz reference up to the Cesium hyperfine frequency, tunable around 9192631770 Hz.
- The Cesium beam tube (CBT), which produces an error signal proportional to the detuning of the RF from the Cesium hyperfine resonance frequency.
- The microprocessor subsystem, which modulates the RF interrogation and steers the quartz oscillator, implements additional servos for magnetic bias (“C-”) field, microwave power, and signal gain, and monitors and reports system health parameters.
- RF and 1 PPS Output buffers
- Cesium beam tube and other secondary power supplies

6.2 Cesium Beam Tube

The heart of the instrument is the Symmetricom Model 7610 Cesium Beam Tube (CBT). The 7610 is a third-generation CBT, reflecting 30 years of continuous manufacture and improvement. The CBT is illustrated schematically in Figure 17 below.

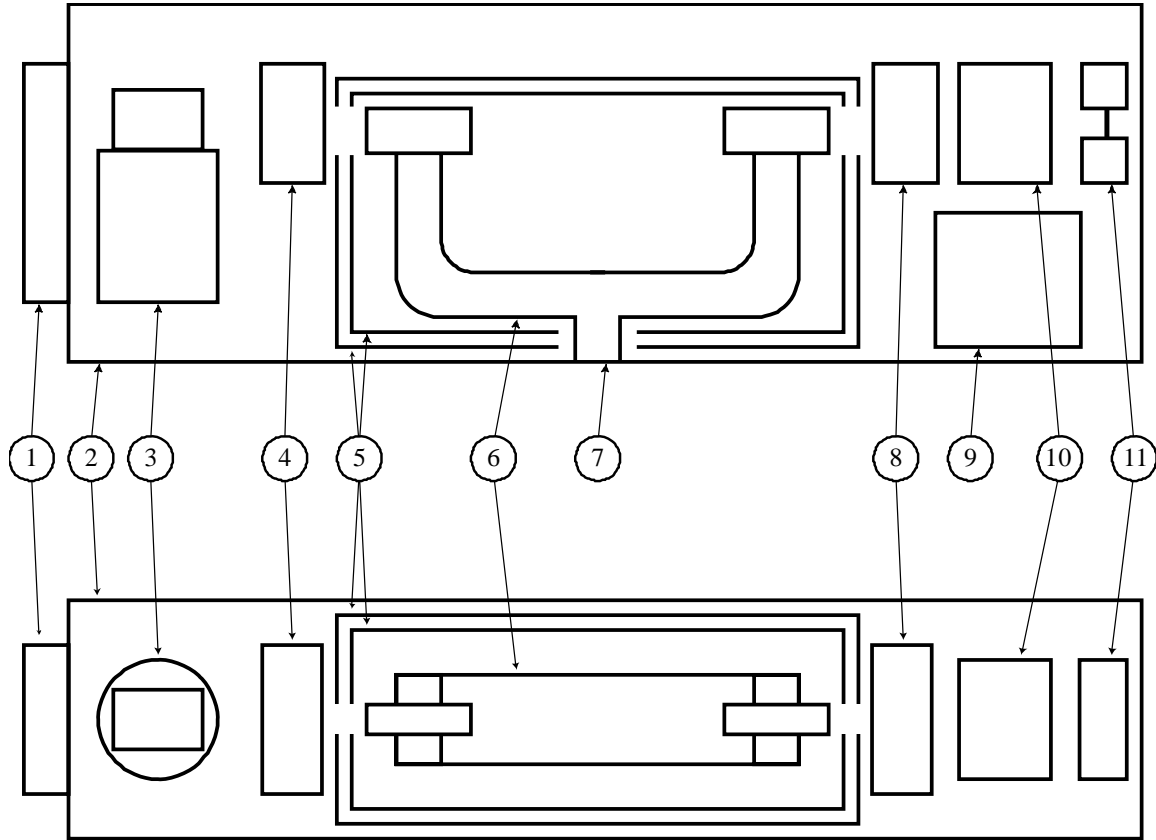

Figure 17 Schematic of the Model 7610 Cesium Beam Tube

Key to Figure 17:

- | | |
|--------------------------|-------------------------|
| (1) Vacuum Ion Pump | (7) RF Input Window |
| (2) Vacuum Jacket | (8) "B" Magnet Assembly |
| (3) Cesium Oven | (9) Electron Multiplier |
| (4) "A" Magnet Assembly | (10) Mass Spectrometer |
| (5) Magnetic Shield (2X) | (11) Hot-Wire Ionizer |
| (6) RF Resonator | |

The key components of the CBT are contained within a welded stainless vacuum vessel (2), wherein an ion pump (1) maintains a high vacuum that minimizes signal attenuation due to collisions between Cesium atoms in the beam and background gas. The Cesium oven (3) contains a volume of Cesium adequate to provide the necessary Cesium beam flux for the lifetime of the CBT. The oven is monitored by a thermistor and maintained at constant temperature by the CBT power supply. A collimator assembly at the output

aperture of the oven forms a beam directed down the axis of the CBT. An inhomogeneous magnetic field, generated by the “A”-magnet state selector (4) separates the beam into two components, each of which is principally composed of atoms in one of the two hyperfine states, $F=3$ or $F=4$. One of these components is directed down the axis of the beam tube while the other is discarded. The beam, composed principally of atoms in the one hyperfine state passes through a double-walled magnetic shield (5) into the resonance interrogation region, within which a small magnetic bias field (the “C-field”) serves to separate the magnetic sub-states of the hyperfine level while maintaining its quantization axis. Within the interrogation region, the atoms pass through the U-shaped resonance cavity (6, the “Ramsey” cavity), which induces a spin-flip resonance response with the characteristic Ramsey pattern (see resonance examples below). Following the resonance interaction, the atoms exit the shielded interrogation region and pass through the second state selector magnet assembly (8, the “B”-magnet), which directs atoms which have undergone the transition to the heretofore unpopulated state into the detector assembly, while rejecting those remaining in the originally selected state. The detector assembly is composed of the hot wire ionizer (10), which effectively strips an electron from the impinging Cesium atoms, creating Cs^+ ions, the mass spectrometer (9), which isolates the Cesium ions from other atomic species, and the electron multiplier (11), which provides amplification of the signal.

The output signal, a current of typically several tens of nanoamperes, is converted to a voltage by a low-noise transimpedance amplifier. The voltage signal is amplified by a digitally controlled variable gain amplifier and then applied to the input of a boxcar integrator whose output is latched and read by a 16-bit analog-to-digital converter (ADC). A single interrogation of the CBT is accomplished by setting the 9 GHz synthesizer to the measurement frequency, enabling the boxcar integrator, waiting for the designated dwell time, and reading the result from the ADC. In the **CsIII**, interrogations are performed at a rate of 38 Hz and with a dwell time of 23 ms.

The Cesium atom possesses a nuclear spin of $I=7/2$. In its unperturbed ground state, the nuclear spin couples with the $S=1/2$ spin of its single valence electron to form two distinct ground states identified by the quantum number $F=I\pm S$, i.e. $F=3$ or $F=4$. Each of these ground states is composed of $(2F+1)$ degenerate Zeeman sub-levels, identified by their projection along an applied magnetic field by the magnetic quantum number m_F , where m_F takes on the integer values from $-F$ to $+F$. The behavior of the Cesium ground state sublevels in an applied magnetic field is shown below in Figure 18.

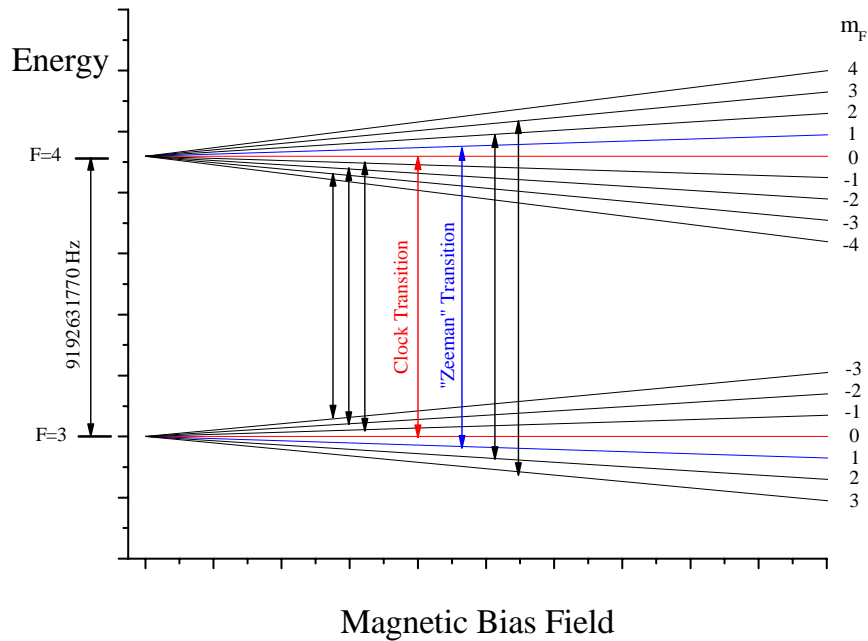

Figure 18 Behavior of the Cesium ground state sublevels in a magnetic field

With the exception of the $m_F=0$ sublevels, all of the energy sublevels exhibit a linear dependence on the applied magnetic field of approximately 350 kHz/Gauss. For this reason, the Cesium beam frequency standard operates on the $F=3, m_F=0 \rightarrow F=4, m_F=0$, “Clock Transition,” whose frequency is, to first order, independent of perturbing magnetic fields. Within the Cesium beam tube, the microwave interrogation is precisely aligned so as to only drive transitions between like sublevels, i.e. $\Delta m_F=0$. There are, thus, seven possible transitions between the $F=3$ and $F=4$ ground states, as shown in **Figure 18**, above. In order to avoid interference of the six field-dependent transitions on the measurement of the clock transition, it is necessary to apply a small bias field, the so-called “C-Field” to the resonance interrogation region. This deliberately shifts the resonance frequency of the field dependent transitions away from the clock transition frequency.

The complete spectrum of the 7610 CBT, showing all seven allowed $\Delta m_F=0$ transitions is shown below in **Figure 19** as the RF frequency is swept across 400 kHz around 9192631770 Hz.

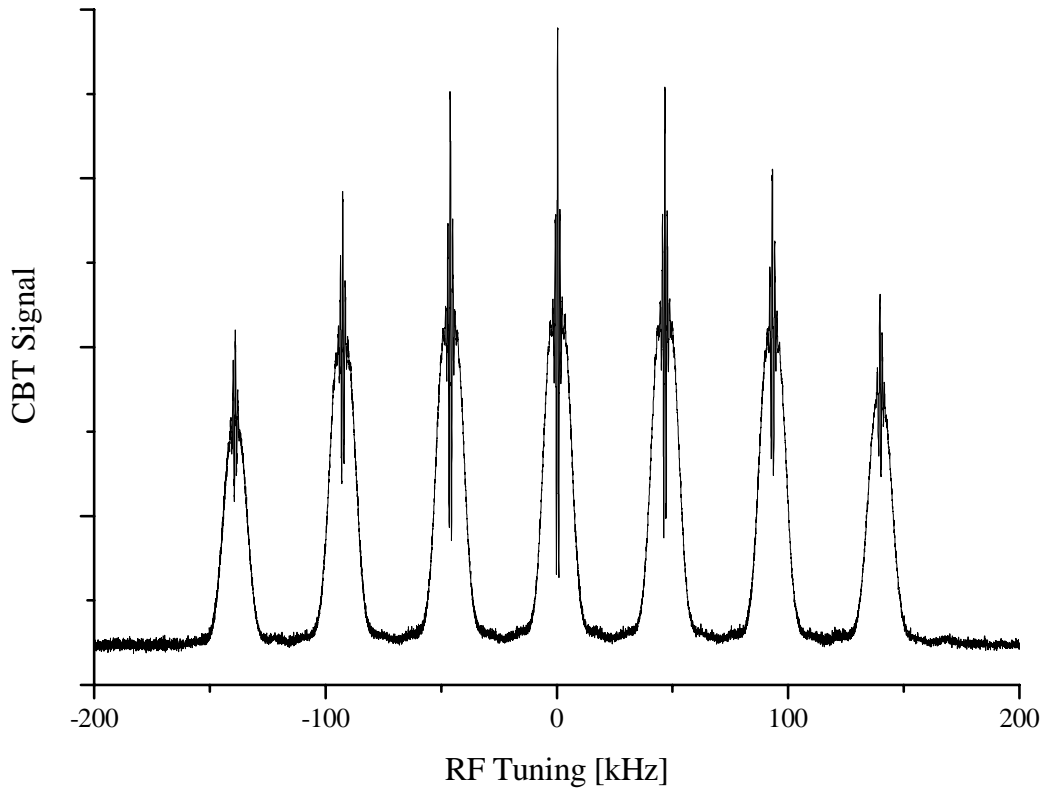

Figure 19 The complete spectrum of the 7610 CBT

The complete 7610 CBT spectrum includes all 7 allowed $\Delta m=0$ magnetic dipole transitions between the Zeeman sublevels of the two ground hyperfine states of Cesium. With the exception of the central, or “Clock” transition, the frequencies of these transitions all exhibit a linear dependence on external magnetic field. The separation between the transitions is provided by the applied C-field and the frequency splitting is termed the “Zeeman frequency,” here 46.4 kHz. The clock transition, which is chosen for its relative insensitivity to applied field, exhibits only a small second-order Zeeman shift. The clock transition is shown in greater detail below.

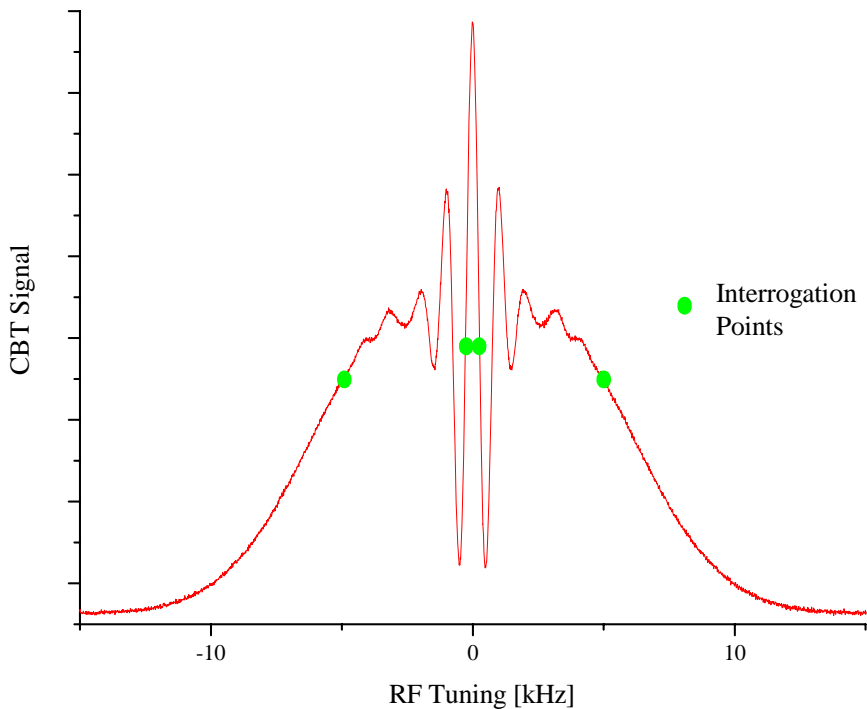

Figure 20 Zeeman Frequency, Clock Transition

The clock transition exhibits the characteristic Ramsey separated oscillatory fields pattern, generated by passing through two spatially separated regions of microwave field at the two ends of the U-shaped resonance cavity. The relatively narrow “Ramsey fringe” exhibits a line width of 500 Hz, dictated by the Fourier transform of the flight time between the two regions. The fringe sits atop the broader “Rabi Pedestal,” whose 10 kHz linewidth reflects the travel time through one of the two regions.

6.3 Clock Servo

The purpose of the clock servo is to steer the control voltage of the ovenized quartz oscillator (OCXO) so that its output frequency (multiplied up to 9192631770 Hz) is aligned with the center of the clock resonance transition, ν_C . A measurement is composed of a pair of interrogations of the CBT response at two points located symmetrically about the clock frequency at the steepest points of the Ramsey fringe, at $\nu = \nu_C \pm 250\text{Hz}$. The **Ramsey Error** signal is the voltage difference (reported in millivolts) between the “left” and “right” interrogations of the Ramsey fringe. The **Ramsey Error** signal is integrated numerically by the microprocessor, using a gain factor determined by the desired loop time constant (factory set to $\tau=1$ second), and applied to the 24-bit digital-to-analog converter (DAC) which controls the tuning voltage of the OCXO so as to drive the **Ramsey Error** to zero. For monitoring purposes, an exponential average of the **Ramsey Error**, with a 1 second time constant, is maintained

by the microprocessor and reported by **Monitor3**. In normal operation, the reported **Ramsey Error** is driven to zero, though occasionally small fluctuations of 1-2 mV may be observed.

As an integrity test, the microprocessor periodically performs a measurement of the **Clock Servo Rabi Error** by performing a pair of interrogations at $\nu = \nu_C \pm 5000\text{Hz}$.

The **Clock Servo Rabi Error** is continuously averaged by the microprocessor with a 100 second time constant. Insofar as the Ramsey fringe is symmetrically positioned atop the Rabi pedestal, this value reads zero. In the unlikely event that the clock servo has locked to the wrong peak of the Ramsey fringe, producing a clock output error of nearly

$\bar{\nu} = 10^{-7}$, the **Clock Servo Rabi Error** would exceed its error threshold of 50 mV, a major alarm (0x02) would be declared, and the unit would perform a restart. In normal operation, the reported value of the **Clock Servo Rabi Error** lies well within +/- 25 mV.

The full tuning range of the OCXO is 5×10^{-7} for an **OCXO Control Voltage** range of 0-5 VDC, which is adequate, in the presence of oscillator aging, to guarantee stable acquisition and lock for the lifetime of the **CsIII** instrument. Typically, upon delivery, the **OCXO Control Voltage** is between 2 and 4 VDC. A minor alarm (0x08) is declared if the **OCXO Control Voltage** falls below 0.5 VDC or rises above 4.5 VDC.

For integration times short compared to the servo loop time constant, the OCXO is essentially free running and thus, provides a reference against which the noise properties of the CBT signal can be measured. The **Signal Deviation** parameter reports the RMS deviation of the measured **Ramsey Error**. This parameter can be taken as a rough indication of the Allan Deviation of the CBT signal. On this time scale, the CBT signal exhibits white Gaussian noise statistics, which lead to $\sigma_y(\tau) \propto \tau^{-1/2}$ and thus, properly scaled, the **Signal Deviation** parameter is proportional to the 1-second Allan deviation of the **CsIII** instrument. The absolute value of the **Signal Deviation**, and thus the scale factor necessary to predict Allan deviation, varies slightly from instrument to instrument. Nonetheless, monitoring this parameter provides a valuable independent indicator of the state-of-health of the instrument. Typically, a standard performance **CsIII** exhibits **Signal Deviation** between 120 and 150. An Enhanced Performance instrument exhibits **Signal Deviation** between 70 and 90.

The relative deviation of the CBT measurements is continuously monitored by the **CsIII** adaptive clock servo algorithm as a measure of **Signal Quality**. If the **CsIII** detects a transient disturbance, which might occur, for example, if the instrument is mechanically disturbed while operating, a minor alarm (0x07) is declared. In this case, the instrument performance is not degraded and the alarm automatically clears when the transient subsides. If the disturbance persists, and instrument performance may be compromised, the minor alarm (0x07) is promoted to a major alarm (0x07).

6.4 Zeeman Servo

As discussed earlier, it is necessary to apply a magnetic bias field (the “C-Field”) to the RF interrogation region in order to prevent the other six transitions in the RF spectrum from interfering with the clock transition. To first order, the magnitude of this field has no (linear) effect on the frequency of the clock transition. There is, however, a second-order shift of the clock transition given by:

$$\nu_C = \nu_0 + \frac{8}{\nu_0} * \delta\nu_Z^2$$

Where ν_0 is the unperturbed clock frequency ($\nu_0=9192631770$ Hz, by definition), and $\delta\nu_Z$ is the Zeeman frequency, defined to be the splitting between adjacent hyperfine transitions and which varies linearly with the applied C-field. In the **CsIII**, the Zeeman frequency, $\delta\nu_Z=46,379.831$ Hz, leading to a corrected clock frequency of $\nu_C=9192631771.8720$ Hz. Thus, the second-order Zeeman correction to the clock frequency is 1.872 Hz, about 2 parts in 10^{10} . The C-field must be held stable to better than 30 ppm in order to guarantee long-term stability of the **CsIII** at the level of 1 part in 10^{14} .

In order to stabilize the C-Field for long-term operation and in the presence of possibly changing external fields, the C-Field current is servoed to the atomic spectrum itself. Periodically, a measurement is made of the Ramsey fringe of the first Zeeman transition to the right of the clock transition, i.e. at $\nu = \nu_C + \delta\nu_Z \pm 250\text{Hz}$. The measurement result is exponentially filtered and used to adjust the **C-Field Control Voltage**, which gently steers the **C-Field Current**, so as to drive the **Zeeman Ramsey Error** to zero. **Monitor3** reports the **Zeeman Ramsey Error**, which averages to zero in normal operation but may vary by +/- 10 mV depending on the presence of time-varying external fields. **Monitor3** also reports the **Zeeman Rabi Error**, which is measured at $\nu = \nu_C + \delta\nu_Z \pm 5000\text{Hz}$.

Because of the high sensitivity of the Zeeman transition to magnetic field, it is not unusual for the **Zeeman Rabi Error** to be as high as +/- 75 mV, particularly in the presence of external magnetic fields near the instrument. If the **Zeeman Rabi Error** exceeds 160 mV, it may indicate that the servo is locked to the wrong Ramsey fringe, leading to a clock offset of 5 parts in 10^{12} . In this case, a major alarm (0x02) will be declared and the **CsIII** will attempt to reacquire the Zeeman servo. **Monitor3** also reports the **C-Field Control Voltage**, which has a range of +/- 2.5 VDC and is set to 0 VDC prior to shipment, as well as the **C-Field Current**, which is measured in mA and reported in the **CBT Supplies** section of the **Monitor3** main panel. Typically, the **C-Field Current** lies between 18.5 and 19.5 mA. If the **C-Field Current** falls below 16 mA or rises above 22 mA, a major alarm (0x05) will be declared.

6.5 Gain Servo

As the CBT ages, the signal level decreases and the level of background signal detected rises. The purpose of the gain servo is to twofold: (a) to guarantee that the resolution of the ADC is fully utilized and (b) to present consistent signal levels to the clock servo, as well as the other measurements and servos. The gain servo is composed of two elements: the digitally controlled hardware gain (**DAC GAIN**) and the software-implemented **Numerical Gain**.

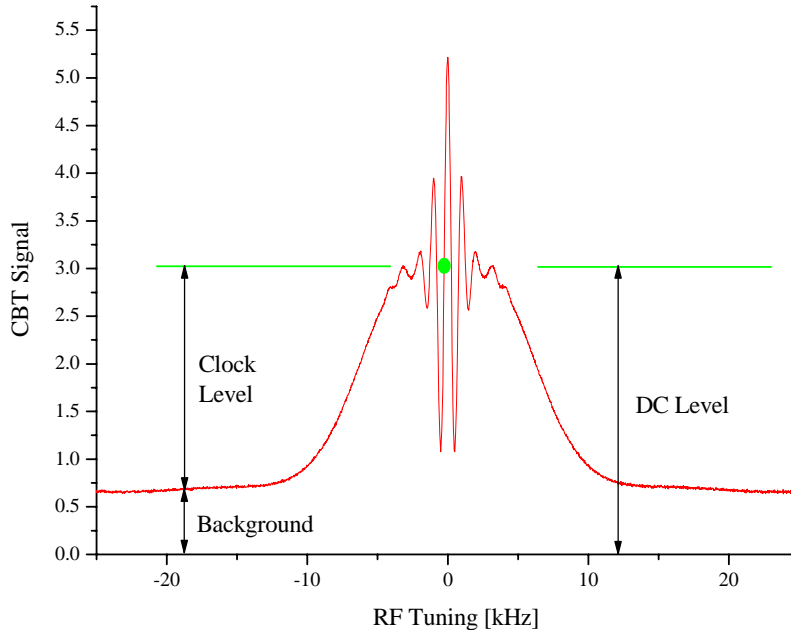

Figure 21 CBT Signal & RF Tuning

The function of the **DAC Gain** is to amplify the **DC Level**, measured at the clock Ramsey interrogation points, to approximately 3 volts, in order to make optimal use of the resolution of the 16 analog-to-digital converter which reads the CBT signal. The **DAC Gain** varies from 1.4 to 256 over the life of the instrument as $256/N$, where N is an integer that varies from 180 to 0. This relatively coarse adjustment is performed only when the **DC Level** falls below 2.0 V or rises above 4.0 V. A minor alarm (0x18) is declared when the **DAC Gain** reaches 256, which indicates that the CBT is nearing the end of its useful life.

The function of the **Numerical Gain** is to present a consistent discriminator slope to the control servos, independent of the signal or background levels or **DAC Gain** adjustment. The **Numerical Gain** is a floating-point number, typically of order 1, which varies continuously throughout instrument life so as to guarantee that the **Clock Level** is 2200 mV. If the **Clock Level** falls below 1320 mV or rises above 3080 mV a major alarm (0x01) is declared.

In normal operation, the **CsIII** periodically measures the background, mid-way between the clock transition and the Zeeman transition. The numerical gain is adjusted continuously and the **DAC Gain** is discretely adjusted if necessary.

6.6 Microwave Power Servo

The short-term stability, accuracy, and environmental sensitivity of the **CsIII** are all optimized when the microwave power in the RF resonator is optimized to provide maximum signal level at the clock Ramsey interrogation points.

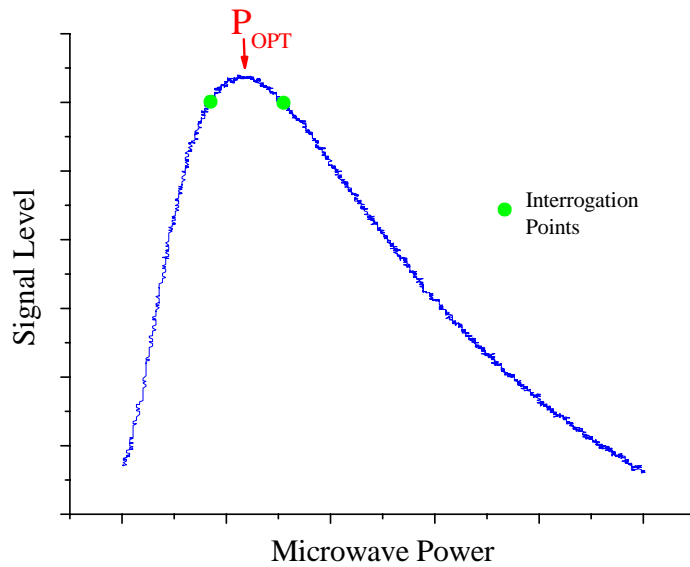

Figure 22 Maximum Signal Level at the Ramsey Interrogation Points

Figure 22 above, shows the microwave power dependence of the 7610 CBT signal, measured at the clock Ramsey interrogation point as the output. The optimum microwave power point, designated P_{OPT} is indicated in the figure. In order to ensure that the microwave power is always optimized, the **CsIII** periodically measures the signal response to small variations of the microwave power, as shown in the figure, alternately performing the measurement on the left- and right-side clock Ramsey interrogation points. This response is input to a digital servo, whose output, the **Microwave Power Control Voltage**, controls a variable attenuator in the microwave synthesizer, higher voltages producing lower output power at 9192 MHz. The range of the **Microwave Power Control Voltage** is 0-5 V and the synthesizer is set in the factory such that P_{OPT} is accomplished near to a setting of 2.5 V. In normal operation the **Microwave Power Control Voltage** may vary from 1.5 to 4 volts, particularly in response to changes in ambient temperature.

6.7 Unit Initialization

Upon power-up, the CsIII performs the following sequence of operations:

Table 6 Warm-up Sequence

	Warm-up Sequence	Completion Indicator
i	Firmware and non-volatile RAM consistency check	RS-232 communication begins
ii	OCXO Oven Warm-up	OCXO Oven changes from “cold” to “Ready”
iii	Cesium Oven Warm-up	Cesium Oven voltage drops below 10 V
iv	Clock Rabi Acquisition	Clock Rabi Error < 40 mV
v	Clock Ramsey Acquisition	Clock Ramsey Error < 40 mV
vi	Gain Servo Initialization	Clock Level > 2000 mV
vii	Zeeman Rabi Acquisition	Zeeman Rabi Error < 40 mV Front panel Lock LED illuminates

Upon completion of the warm-up sequence, the offset frequency of the instrument is expected to meet its specified accuracy, though it may continue to move by several parts in 10^{13} over the first several hours of operation as the instrument temperature equilibrates and the Zeeman, gain, and microwave power servos converge on their optimum values.

6.8 Alarms and Indicators

In addition to the system monitors relating to servos and Cesium beam tube parameters, discussed in earlier sections of this chapter, periodic measurements are made of primary and secondary system voltages and CBT power supplies. These are generally self-explanatory from the front panel of Monitor3. The complete list of possible alarm conditions is shown in Table 7.

Table 7 Alarm Descriptions, Conditions, and Level

Alarm	Description	Error Condition	Level	Ref
0x01	Clock Fringe Level	< 1320 mV or >3080 mV	MAJOR	6.5
0x02	Clock Rabi Asymmetry	> 50 mV	MAJOR	6.3
0x03	Zeeman Rabi Asymmetry	> 160 mV	MAJOR	6.4
0x04	Mass Spec Voltage	+/-5% of factory setting	MAJOR	
0x05	Cfield Current	< 16 mA or > 22 mA	MAJOR	6.4
0x06	EM Voltage	Control <7 V or >13V	MAJOR	
0x07	CBT Signal Quality	Signal Quality degraded	MINOR/MAJOR	6.3
0x08	VCXO Tuning voltage	<10% or >90% of range	MINOR	6.3
0x09	Ambient Temp	> 80°C	MAJOR	
0x12	5V Supply	< 4.75V or > 5.25 V	MAJOR	
0x13	Positive 15 V Supply	< 13.75 V or > 17.0 V	MAJOR	
0x14	Negative 15 V Supply	> -13.75 V or < -17.0 V	MAJOR	
0x16	Unit Restart	Set on Reboot	MINOR/MAJOR	4.6
0x17	Module Configuration	Checksum failure on Reboot	Informative only	
0x18	DAC Gain at Maximum	= 256	MINOR	
80	Software Failure		MAJOR	
81	Event Log Invalid	Checksum failure on Reboot	Informative only	
0xF1	Cesium Oven Voltage	> 10.0 V (after Cs lock)	MAJOR	
0xF2	Oscillator Oven Warm-up	Unlock (after Cs lock)	MAJOR	
0xF3	Ionizer Voltage	>±160 mV off factory setting	MAJOR	
0xF4	Ion Pump Current	> 175 μ A	MAJOR	
0xF5	21 V Power Supply	< 17 V or > 24 V	MAJOR	

Appendix A - Specifications

A.1 Electrical Specifications

Frequency Outputs

One each 5 & 10 MHz Sine

Amplitude:	1 VRMS
Harmonic:	< -40 dBc
Non-harmonic:	< -80 dBc
Connector:	Type N
Load impedance:	50 Ohms
Location:	Rear Panel

One 10 MHz TTL

Amplitude:	>2.2V
Connector:	BNC
Load impedance:	50 Ohms
Location:	Rear Panel

Timing Output

Format:	1 PPS
Amplitude:	>3.0V into 50 Ohms
Pulse width:	20s positive pulse
Rise time:	<5 nS
Jitter:	<1 nS RMS
Connector:	BNC
Load impedance:	50 Ohms
Location:	Rear Panel

Timing Input

Sync input:	1 PPS
Connector:	BNC
Load impedance:	50 Ohms
Location:	Rear Panel

RS-232 System Interface and Control

RS-232-C (DTE):	9-pin male rectangular D subminiature type
Location:	Rear Panel

Alarm interface

Alarm (Relay):	DB9 female (Rear Panel)
----------------	-------------------------

A.2 Performance Specifications**Performance**

Accuracy:	+/-1.0E-12
Warm-up time:(typical)	30 Min.
Reproducibility:	+/-2.0E-13
Settability Range:	+/-1E-9
Settability Resolution:	1E-15

Stability

Avg Time (s)	Allan Deviation
1	<1.2E-11
10	<8.5E-12
100	<2.7E-12
1,000	<8.5E-13
10,000	<2.7E-13
100,000	<8.5E-14
Floor	<5.0E-14

SSB Phase noise

Offset (Hz)	5 MHz Output
1	<-95 dBc
10	<-130 dBc
100	<-145 dBc
1,000	<-155 dBc
10,000	<-155 dBc
100,000	<-160 dBc

A.3 Environmental & Physical Specifications

General Environment

Operating	
Temperature:	0° C to 50° C
Humidity:	95% up to 50° C, Non-Condensing
Non-operating (transport)	
Temperature (storage):	-40° C to 70° C
Temperature (short term):	-40° C to 75° C
Magnetic field:	0 to 2 gauss
Altitude (operating):	0 to 50,000 feet

AC Power Requirements

Voltage:	85 to 264 VAC
Frequency:	47 to 63 Hz
Power (Operating):	65W
Power (Warm Up):	90W
AC Fuse (F1):	Fuse, Slow, 2.0A, 250V, M5x20 (part # 45-00030-02R0)

DC Power requirements

Input Voltage:	36 - 75VDC*
Power (Operating):	30W
Power (Warm up):	65W
DC Fuse (F2):	Fuse, Slow, 4.0A, 250V, M5x20 (part # 45-00030-04R0)

* 24VDC (18 - 36VDC) Power supply option available

DC Mating Connector: Cannon type MS3106E14S-5S

Dimensions

Height:	3.5" (88.9 mm)
Width:	
Front panel:	19" (483 mm)
Instrument:	17.31" (440 mm)
Depth:	15" (381 mm)
Weight:	<30lbs (13.5 kg)

Options

Telecom Synthesizer:	See manual 15004-201
Portability Kit:	See manual 14950-201

Appendix B - Programmer's Guide

In certain specialized applications, users may wish to develop customized interface and control software, rather than **Monitor3**. This section describes the protocol for the RS-232 Interface and includes general communication parameters as well as the command list. Note that this section is designed for experienced programmers and assumes a general knowledge of RS-232 interface programming.

B.1 General Parameters

The **CsIII**'s factory-default RS-232 settings, modifiable using the C05 command, are:

Configuration:	DTE
Data Bits:	8
Parity:	None
Stop Bits:	1
Baud Rate:	9600

B.2 Restart Message

Upon restart the DCC transmits the following message to the RS-232 Port:

```
<STX>Symmetricom_CsIII:_system_start<ETX>
```

Element	Description
<STX>	ASCII 0x02
_	Space Character
<ETX>	ASCII 0x03

B.3 Cesium Command Reference

Commands are sent to the **CsIII** over the RS-232 port. The command set is backwards compatible with Symmetricom instruments based on the 4201A/5045 architecture (4040, 4065). Several new commands support the new capabilities of the CsIII. General format:

```
<STX>_<Function Code>_<IDENT>_<DATA><ETX>
```

Element	Description
STX	002
_	Space character
<Function Code>	Function code, see table
<IDENT>	5 character unit identification number
[<DATA>]	Data: this string is of variable length
ETX	003

All entries in the data field are left justified, and the remainder (if any) of the Data field must be filled in, to round it up to 9 characters in length. All commands sent to the **CsIII** return a response of the form:

<STX><Text of response><ETX>

Table 8, below, lists all commands recognized by the CsIII.

If the CsIII receives a malformed or non-compliant command or if the command addresses an optional feature which is not currently installed (i.e. commands which address features particular to other Symmetricom Cesium instruments), the CsIII performs no action and echoes the command back to the user with an additional space character and question mark character appended prior to the closing <ETX> character. For example:

Transmission:

```
<STX>C05_00000_1900,8,N,1<ETX> (error in Baud rate datafield)
```

CsIII Response:

```
<STX>C05_00000_1900,8,N,1 ?<ETX>
```

Table 8 defines the CsIII interface. The right hand column, “Notes” refers to the detailed descriptions following the table.

WARNING...

Many of the function codes listed in the following tables are labeled “Reserved for Factory Use” and are intended only for factory calibration and test of the CSIII instrument. Issuance of commands labeled “Reserved for Factory Use” may render the CSIII inoperable and void the warranty.

Table 8 CsIII Command Reference

CMD	Description	Data Field	Reference Section
W00	Reset alarms	No data required	4.6
W01	Set frequency offset (permanent, value is saved in NVRAM and restored on power up). The offset is in parts in 10-15	Sign plus 6 digits	4.3
W02	** Reserved for Factory Use **		
W03	Phase Offset (advance or retard 10 MHz phase by N nanoseconds)	Sign plus 4 digits	4.5
W04	Halt phase offset operation.	No data required	4.5
W05	** Reserved for Factory Use **		
W06	** Reserved for Factory Use **		
W08	** Reserved for Factory Use **		
W10	** Reserved for Factory Use **		
W11	Set Temporary frequency offset (not saved in NVRAM). The offset is in parts in 10-15	Sign plus 6 digits	
W12	** Reserved for Factory Use **		
W13	** Reserved for Factory Use **		
W14	** Reserved for Factory Use **		
W17	Alarm Relay Cutoff	No data required	
W18	** Reserved for Factory Use **		
W22	Arm 1 PPS Sync circuit. Issue this command after connecting a 1 PPS source to the CsIII. The sync will remain armed for 3 seconds.	No data required	4.4
D*1	Return Variables (250 characters)	No data required	
D*2	Return Constants (145 characters)	No data required	
D*3	** Reserved for Factory Use **		
D*4	** Reserved for Factory Use **		
D*5	Return NVRAM Contents		
C01	** Reserved for Factory Use **		
C02	** Reserved for Factory Use **		
C03	Return software version	No data required	
C04	** Reserved for Factory Use **		
C05	Set serial port parameters	Baud, data, parity, stop bits	4.8
C06	** Reserved for Factory Use **		
S01	** Reserved for Factory Use **		
S02	** Reserved for Factory Use **		
S03	** Reserved for Factory Use **		
S04	** Reserved for Factory Use **		
S05	** Reserved for Factory Use **		
S06	** Reserved for Factory Use **		

CMD	Description	Data Field	Reference Section
S07	** Reserved for Factory Use **		
S08	** Reserved for Factory Use **		
S09	** Reserved for Factory Use **		
A01	** Reserved for Factory Use **		
A02	** Reserved for Factory Use **		
A03	** Reserved for Factory Use **		
A04	** Reserved for Factory Use **		
A05	** Reserved for Factory Use **		
A06	** Reserved for Factory Use **		
A07	** Reserved for Factory Use **		
A08	** Reserved for Factory Use **		
A09	** Reserved for Factory Use **		
A10	** Reserved for Factory Use **		
A11	** Reserved for Factory Use **		
A12	** Reserved for Factory Use **		
A13	** Reserved for Factory Use **		
A14	Return power on hours	No data required	
A15	** Reserved for Factory Use **		
A16	** Reserved for Factory Use **		
A17	** Reserved for Factory Use **		
A18	Set Restart Fault Level	1 = restart is critical fault 0 = restart not critical fault	4.6
A19	** Reserved for Factory Use **		
A20	** Reserved for Factory Use **		
A21	** Reserved for Factory Use **		
A22	** Reserved for Factory Use **		
A23	** Reserved for Factory Use **		
A24	** Reserved for Factory Use **		

Notes:**W00 Clear Alarms**

Clears all pending alarms. The return value is an echo of the received command.

C05 Set Serial Port parameters

Sets the serial port parameters to new settings. For example:

```
<STX>C05_00000_19200,8,N,1<ETX>
```

Return the return value would be similar to the following:

```
Setting Serial Parameters to XXXX, 8,N,1
```

Where XXXX is new baud rate setting.

Table 9 Data returned by the “Return Variables” command D*1

Variable	Field	Example
STX CR LF	1-3	
Unit serial number	4-10	ID00025
Space	11	
Day Meter	12-14	537
Space	15	
Time (hour minute second)	16-25	16h13mn22s
Space	26	
First or second order servo loop	27	1
Space	28	
Operating mode	29-31	R+Z
Space	32	
Alarms state	33-54	ALM:00(00,00,00,00,00)
C-Field adjustment	55-59	C +015
Space	60	
Frequency fine tuning	61-68	F -006
Space	69	
+21VDC power supply	70-76	+24.8V
Space	77	
Filtering time constant (seconds)	78-83	Ct05.0
CR LF	84-85	
Clock servo voltage difference	86-90	R-019
Clock pedestal servo voltage difference	91-98	RR +0045
Zeeman servo voltage difference	99-103	Z+008
Zeeman pedestal servo voltage difference	104-111	RZ -0004
Oscillator servo output voltage	112-118	AR-0029
Clock peak to background level difference	119-124	PR2506
Zeeman servo output voltage	125-131	AZ+0007
Zeeman peak to background level difference	132-137	PZ1765
Preamplifier DC level servo output voltage	138-144	A0 + 0690
Numerical gain	145-151	GN*1.53
Clock (Ramsey) peak symmetry check	152-158	LA-0005
Microwave power servo control voltage	159-165	Pu-2875
CR LF	166-167	
+5V power supply	168-173	+5.08V
Space	174	
Internal case temperature	175-180	T+27.7
Space	181	
+15.5V power supply	182-187	+15.1V
Space	188	
-15.5v power supply	189-194	-16.2V
Quartz oscillator cold/warm	196-198	Olc
Space	199	
Cesium oven supply voltage	200-205	F008.0
Space	206	
Mass spectrometer voltage	207-212	VS18.9
Space	213	

CsIII User Guide

Cesium beam tube Ionizer voltage	214-219	VF1.05
Space	220	
C-Field coil current	221-226	IC14.5
Space	227	
HTEM control voltage	228-233	HT10.6
Space	234	
Ion Pump current	235-239	IP025
Space	240	
Allan deviation of clock servo voltage over 30 seconds	241-247	+137 mV
CR LF ETX	248-250	

Table 10 Data returned by the “Return Constants” command D*2

Variable	Field	Example
STX CR LF	1–3	
Unit serial number	4–10	ID00025
Space	11	
Day Meter	12–14	006
Space	15	
Time (hour minute second)	16–24	04h54mn32s
Space	25	
Spectrometer voltage nominal	26–33	Vs 14.0V
Space	34	
Tube ionizer voltage nominal	35–42	Vf 1.07V
Space	43	
Gain DAC	44–51	GDAC 008
Space	52	
F(t°) correction model at –15°C	53–59	–15:+10
Space	60	
F(t°) correction model at +15°C	61–67	+15:+00
Space	68	
F(t°) correction model at +45°C	69–75	+45:–03
Space	76	
F(t°) correction model at +75°C	77–83	+75:+04
CR LF	84–85	
12.6 MHz level nominal (J1 max)	86–92	Pi+0345
Space	93	
Zeeman offset (Asymmetry compensation)	94–100	Oz–0045
Space	101	
Auxiliary output signal frequency	102–112	Fo:05.0 MHz
Space	113	
Console mode language	114–119	CDU: UK
Space	120	
Comments	121–133	TXT(1234567890)
Space	134	
Space	135	
program version	136–138	370
Space	139	
program revision	140–142	1.8
CR LF ETX	143–145	

Event Log

A portion of the non-volatile memory in the system is reserved for storage of event records. Event records consist of a time stamp and an event mask. Any change in the system status is recorded as a new event in the log. The event log can be cleared by an external command. Because the CSIII lacks a battery backed up real time clock, the Event log stores two distinct time stamps. The first is a 6-byte calendar date; the second is a 32-bit value representing the total system power on hours.

Appendix C - Customer Assistance/Technical Support

Assistance can be obtained by contacting us as follows:

<mailto:support@symmetricom.com>

<http://www.symmetricom.com/support>

Worldwide (Main Number): 1-408-428-7907

USA, Canada, Latin America, Caribbean, Pacific Rim, Asia, Australia, and New Zealand:

1-408-428-7907

USA toll-free: 1-888-367-7966 (1-888-FOR-SYMM)

Europe, Middle East & Africa: 49 700 32886435

Appendix D - Declaration of Conformity

DECLARATION OF CONFORMITY	
<i>Application of Council Directive(s): 73/23/EEC</i>	
<i>Standard(s) to which Conformity is Declared:</i>	
EN61010-1 (EN 60950:1992, Including Amendment Nos. 1,2,3,4,11)	
<i>Manufacturer's Name</i>	Symmetricom
<i>Manufacturer's Address</i>	34 Tozer Road Beverly, MA 01915
<i>Importer's Name</i>	
<i>Importer's Address</i>	
<i>Type of Equipment</i>	Class I
<i>Model Number</i>	4310A
<i>Serial Number</i>	See Serial Number Label
<i>Year of Manufacture</i>	See first two digits of Serial Number Label (Example: 99 = 1999)
<p>I, the undersigned, hereby declare the equipment specified above conforms to the above identified standard(s) as described in the test record.</p>	
<i>Place</i>	Symmetricom - Beverly
	 (Signature)
<i>Date</i>	<u>December 17, 2000</u>
	<u>David Holbert</u> (Full Name)
	<u>Director, Quality Assurance</u> (Position)